



Hamilton
Public Works

CITY OF HAMILTON

BARRIER-FREE DESIGN GUIDELINES

VERSION 1.1

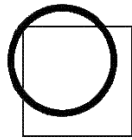

2006

Hamilton Public Works ~ Providing services that bring our City to life!



Hamilton

February 14, 2006

Message from the City Manager

On behalf of the City of Hamilton, I am pleased to present to you the newly revised City of Hamilton's Barrier-Free Design Guidelines 2006 which are to be used by all Departments and/or Divisions currently involved in the planning, design, or construction of all newly constructed and/or renovated City of Hamilton owned, leased, or operated facilities, parks and open spaces, and infrastructure (including urban design, traffic, roads etc.)

The original Barrier-Free Design Standards were completed in 1994 by the Barrier-Free Design Standards Sub-Committee. Their mandate to the City of Hamilton was as follows:

"To provide the community with a set of design standards that will lead to the elimination of barriers facing persons with various disabilities in the built environment."

I am very pleased to say that these newly revised Guidelines have maintained the original intent of this mandate, in providing an up-to-date set of standards which will assist in the reduction or elimination of all barriers faced by persons with disabilities within our Community.

As there was a tremendous effort by all parties involved in the production of this document, including Staff from a variety of Departments and Divisions, R.F. Lintack Architect Inc., the Advisory Committee for Persons with Disabilities, and the Barrier-Free Design Standards Committee, I would like to express my appreciation to everyone involved on this project.

Sincerely,

A handwritten signature in black ink that reads "Glen Peace".

Glen Peace
City Manager



City of Hamilton
City Hall, 71 Main Street West
Hamilton, Ontario,
Canada L8P 4Y5
www.hamilton.ca

Advisory Committee for Persons with Disabilities
c/o Customer Service, Access & Equity Division

Hamilton

February 7, 2006

Mr. Clark Euale
Public Works Department
Capital Planning & Implementation
City of Hamilton
Suite 320 – 77 James St North
Hamilton ON L8R 2K3

RE: Barrier-Free Design Guidelines Report

This letter will acknowledge that on December 6, 2005, staff from R.F. Lintack Architect and the City of Hamilton's Capital Planning & Implementation Division attended the Advisory Committee for Persons with Disabilities for the City of Hamilton's meeting to present the draft and consult with the Committee on revisions made to the Barrier-Free Design Guidelines document.

The Advisory Committee provided comments at the meeting. It was agreed that the Committee's comments and suggestions would be incorporated into the Barrier-Free Design Guidelines document and that a copy of the final document would be provided to the Committee for their information.

I would like to take this opportunity to thank the staff and consultants for their extensive consultation process, which included a number of our committee members, and note that we are looking forward to working with the new standards and to further consultation as updates become necessary.

The approval and implementation of the revised Barrier-Free Design Guidelines document is a very important City initiative towards the elimination of barriers for persons with disabilities, and a significant move towards enabling a higher level of participation in civic and community life for all members of our community.

Sincerely,

A handwritten signature in black ink, appearing to read "Tim Nolan".

Tim Nolan, Chair
Advisory Committee for Persons with Disabilities
for the City of Hamilton

Guideline Developments

The City Of Hamilton's Barrier-Free Design Guidelines – 2006 were developed by R. F. Lintack Architect Incorporated with the support and direction from the City of Hamilton Department of Public Works, Capital Planning and Implementation Division, along with numerous Project Stakeholders including representation from many City Departments and their respective Divisions; the Barrier-Free Guidelines Committee; and the Advisory Committee for Persons with Disabilities (see Appendix A – Acknowledgements, page 213).





PART I INTRODUCTION and BACKGROUND

1.0	Introduction	1
2.0	Universal Design Principles and Guidelines	3
3.0	Scope, Application and Enforcement	5
4.0	Glossary and Definitions	7

PART II DESIGN GUIDELINES..... **13**

5.0	Physical Accessibility	15
5.1	<u>Access and Circulation</u>	17
5.1.1	Space and Reach Requirements	19
5.1.2	Ground and Floor Surfaces	23
5.1.3	Protruding Objects.....	25
5.1.4	Accessible Routes, Paths and Corridors.....	27
5.1.5	Exterior Pedestrian Routes	31
5.1.6	Vehicular Access	37
5.1.7	Signals at Crosswalks	41
5.1.8	Entrances.....	43
5.1.9	Doors	47
5.1.10	Gates, Turnstiles and Openings	53
5.1.11	Interior Routes	55
5.1.12	Ramps	57
5.1.13	Stairs.....	61
5.1.14	Handrails	63
5.1.15	Escalators	65
5.1.16	Elevators.....	67
5.1.17	Platform Lifts	73
5.2	<u>Washroom Facilities</u>	75
5.2.1	Toilet and Bathing Facilities	77
5.2.2	Toilet Stalls.....	81
5.2.3	Toilets	85
5.2.4	Lavatories	87
5.2.5	Urinals	89
5.2.6	Individual Washrooms	91
5.2.7	Washroom Accessories	93
5.2.8	Bathtubs	95
5.2.9	Shower Stalls.....	97
5.2.10	Grab Bars.....	103
5.3	<u>Amenities</u>	105
5.3.1	Street Furniture	107
5.3.2	Public Telephones	109
5.3.3	Waiting and Queuing Areas	111
5.3.4	Information, Reception and Services Counters.....	113
5.3.5	Offices and Work Areas	115
5.3.6	Tables, Counters and Work Surfaces.....	117
5.3.7	Drinking Fountains	119
5.3.8	Lockers	121
5.3.9	Ticketing Machines	123





5.4	<u>Systems and Controls</u>	125
5.4.1	Controls and Operating Mechanisms	127
5.4.2	Emergency Exits, Fire Evacuation and Areas of Rescue Assistance.....	129
6.0	Visual Accessibility	131
6.1	Glare and Light Sources	133
6.2	Lighting	135
6.3	Materials and Finishes	137
6.4	Texture and Colour	139
6.5	Urban Braille	141
6.6	Information Systems.....	145
6.7	Signage and Wayfinding.....	147
6.8	Detectable Warning Surfaces.....	151
6.9	Windows, Glazed Screens and Sidelights	153
7.0	Audible Accessibility	155
7.1	Acoustics	157
7.2	Public Address Systems	159
7.3	Audible Signals	161
7.4	Assistive Listening Systems	163
7.5	Visual Alarms	165
8.0	Special Facilities and Areas	167
Building types not included in this Section are not exempt from applicable criteria within this guideline		
8.1	Meeting Rooms, Assembly Areas and Theatres	169
8.2	Display, Exhibition Areas, Galleries and Museums.....	171
8.3	Outdoor Recreation Facilities	173
8.4	Municipal Courts	177
8.5	Gymnasiums.....	179
8.6	Libraries	181
8.7	Cafeterias, Restaurants, Dining Areas and Bars	185
8.8	Arenas	187
8.9	Ice Rink.....	189
8.10	Swimming Pools	191
8.11	Police Stations.....	195
8.12	Long Term Care Facilities and Senior's Housing	197
8.13	Clinics	199
8.14	Residential Kitchens	201
8.15	Residential Bathrooms	203
8.16	Residential Bedrooms	205
8.17	Transit Facilities.....	207
8.18	Airports	209
9.0	Appendices	211
A	Acknowledgments	213
B	Bibliography	219
C	Change Request Form.....	221





The City Of Hamilton has historically been proactive in accommodating the needs of persons with disabilities.

Originating in 1985, as a response to provincial employment equity legislation, the Barrier Free Design Sub-Committee was formed. Its Mission Statement was to “provide the community with a set of design guidelines that will lead to the elimination of barriers facing persons with various disabilities in the built environment.”

Unable to find a single Standard that was complete or satisfactory, the Sub-Committee's mandate was transformed to put together a set of guidelines which, when applied, “shall provide the Region and the City with a complete and satisfactory set of Barrier Free Design Guidelines.” It was adopted by Hamilton-Wentworth Regional Council and Hamilton City Council in 1994 and was to be applied to all city-owned and leased facilities. It was to be reviewed every 3 to 5 years in order to maintain its status with advances in technology.

In 2001, the Province of Ontario passed the Ontarians with Disabilities Act. The purpose of the act is to “improve opportunities for persons with disabilities and to provide for their involvement in the identification, removal and prevention of barriers to their full participation in the life of the province.” The ODA defines a disability as:

- Any degree of physical disability, infirmity, malformation or disfigurement that is caused by bodily harm, birth defect or illness and, without limiting the generality of the foregoing, includes diabetes mellitus, epilepsy, a brain injury, any degree of paralysis, amputation, lack of physical coordination, blindness or visual impediment, deafness or hearing impediment, muteness or speech impediment, or physical reliance on a guide dog or other animal or on a wheelchair or other remedial appliance of device.
- A condition of mental impairment or
- A developmental disability,
- A learning disability, or a dysfunction in one or more of the processes involved in understanding or using symbols or spoken language
- A mental disorder, or
- An injury of disability for which benefits were claimed or received under the insurance plan established under the Workplace Safety and Insurance Act, 1997; (“handicap”)

The ODA defines a barrier as:” anything that prevents a person with a disability from fully participating in all aspects of society because of his or her disability, including a physical barrier, an architectural barrier, an informational or communications barrier, an attitudinal barrier, a technological barrier, a policy or a practice; (obstacle).

In response to the ODA the City of Hamilton established the Advisory Committee for Persons with Disabilities. Among its many recommendations the Committee has recommended the update of the City's Barrier-Free Design Guidelines. Recognizing that the Guidelines are over 10 years old, and that augmentative and support equipment for persons with disabilities has changed over that timeframe. New alternatives may be available to accommodate the needs of persons with disabilities and guidelines may need to change to accommodate these changes in the technical and functional supports for persons with disabilities.

The Barrier-Free Design Guidelines 2006 is intended for use by all Departments and Divisions of the City of Hamilton; involved in the planning, design, construction, and maintenance of physical facilities, including buildings, parks and open spaces, infrastructure, and any other space that is to be open and fully



accessible to the Public. It is envisaged that the Guideline will be utilized by building owners, architects, engineers, designers and those interested in the reduction or elimination of barriers faced by persons with disabilities within the built environment. In light of this, this Guideline was developed to be a flexible, ever changing document, which may be utilized as a reference by both the Public and Private Sectors.

The Guideline identifies barriers and obstacles, and presents design requirements that, consistent with the Ontario Building Code (O.B.C. 1997), should be considered as a minimum requirement for all City of Hamilton projects.

Users of this Guideline are encouraged to consider it a “performance guideline” and to provide alternate design solutions that are equivalent or exceed the ability to access a public space.

Inherent in the Guideline is the concept of Universal Design – the design of products and environments to be usable by all people to the greatest extent possible, without the need for adaptation or specialized design. In this spirit, the Guideline is intended to meet the access requirements for not only the physically disabled, but also the older people, the parent with a stroller, the person delivering a large package, and the young child.

The City of Hamilton will be updating this document on a yearly basis. Users are encouraged to utilize the [Change Request Form in Appendix C](#) (page 221) of this document, and submit all change requests to the attention of:

**The City of Hamilton's
Customer Service,
Access & Equity,
Corporate Services Department**



Universal Design Principals and Guidelines 2.0

UNIVERSAL DESIGN:

The design of products and environments to be usable by all people, to the greatest extent possible, without the need for adaptation or specialized design.

The authors, a working group of architects, product designers, engineers and environmental design researchers, collaborated to establish the following Principles of Universal Design to guide a wide range of design disciplines, including environments, products, and communications. These seven principles may be applied to evaluate existing designs, guide the design process and educate both designers and consumers about the characteristics of more usable products and environments.

The Principles of Universal Design are presented here, in the following format: name of the principle, intended to be a concise and easily remembered statement of the key concept embodied in the principle; definition of the principle, a brief description of the principle's primary directive for design; and guidelines, a list of the key elements that should be present in a design which adheres to the principle. (Note: all guidelines may not be relevant to all designs.)

PRINCIPLE ONE: Equitable Use

The design is useful and marketable to people with diverse abilities.

Guidelines:

- 1a. Provide the same means of use for all users: identical whenever possible; equivalent when not.
- 1b. Avoid segregating or stigmatizing any users.
- 1c. Provisions for privacy, security, and safety should be equally available to all users.
- 1d. Make the design appealing to all users.

PRINCIPLE TWO: Flexibility in Use

The design accommodates a wide range of individual preferences and abilities.

Guidelines:

- 2a. Provide choice in methods of use.
- 2b. Accommodate right- or left handed access and use.
- 2c. Facilitate the user's accuracy and precision.
- 2d. Provide adaptability to the user's pace.

PRINCIPLE THREE: Simple and Intuitive Use

Use of the design is easy to understand, regardless of the user's experience, knowledge, language skills, or current concentration level.

Guidelines:

- 3a. Eliminate unnecessary complexity.
- 3b. Be consistent with user expectations and intuition.
- 3c. Accommodate a wide range of literacy and language skills.
- 3d. Arrange information consistent with its importance.
- 3e. Provide effective prompting and feedback during and after task completion.

PRINCIPLE FOUR: Perceptible Information

The design communicates necessary information effectively to the user, regardless of ambient conditions or the user's sensory abilities.

Guidelines:

- 4a. Use different modes (pictorial, verbal, tactile) for redundant presentation of essential information.
- 4b. Provide adequate contrast between essential information and its surroundings.
- 4c. Maximize "legibility" of essential information.
- 4d. Differentiate elements in ways that can be described (i.e., make it easy to give instructions or directions).
- 4e. Provide compatibility with a variety of techniques or devices used by people with sensory limitations.

PRINCIPLE FIVE: Tolerance for Error

The design minimizes hazards and the adverse consequences of accidental or unintended actions.

Guidelines:

- 5a. Arrange elements to minimize hazards and errors: most used elements, most accessible; hazardous elements eliminated, isolated, or shielded.
- 5b. Provide warnings of hazards and errors.
- 5c. Provide fail-safe features.
- 5d. Discourage unconscious action in tasks that require vigilance.



Universal Design Principals and Guidelines 2.0

PRINCIPLE SIX: Low Physical Effort

The design can be used efficiently and comfortably and with a minimum of fatigue.

Guidelines:

- 6a. Allow user to maintain a neutral body position.
- 6b. Use reasonable operating forces.
- 6c. Minimize repetitive actions.
- 6d. Minimize sustained physical effort.

PRINCIPLE SEVEN: Size and Space for Approach and Use

Appropriate size and space are provided for approach, reach, manipulation, and use, regardless of user's body size, posture, or mobility.

Guidelines:

- 7a. Provide a clear line of sight to important elements for any seated or standing user.
- 7b. Make reach to all components comfortable for any seated or standing user.
- 7c. Accommodate variations in hand and grip size.
- 7d. Provide adequate space for the use of assistive devices or personal assistance.

Please note that the Principles of Universal Design address only universally usable design, while the practice of design involves more than consideration for usability. Designers must also incorporate other considerations, such as economic, engineering, cultural, gender, and environmental concerns, in their design processes. These principles offer designers guidance to better integrate features that meet the needs of as many users as possible.

© Copyright 1997 NC State University,
The Center for Universal Design



Scope, Application, and Enforcement 3.0

GENERAL

The City of Hamilton's Barrier-Free Design Guideline 2006, was developed to be a flexible, ever changing document, which illustrates multiple levels of accessibility, beginning with the preferred option, and working down gradually to the lowest guideline; being the O.B.C. (1997). It is hoped that by providing multiple levels of accessibility within this document, it will encourage its use by both Public and Private Sectors, thus promoting an accessible community for persons with disabilities.

The requirements of this guideline shall be

- encouraged for all newly constructed and retrofitted facilities owned, leased or operated by the City of Hamilton; and
- encouraged for all other facilities, whether new or retrofitted.

Exceptions: This guideline does not apply to

- residential occupancies;
- buildings of Group F Division 1 occupancy, as defined by the Ontario Building Code (latest edition with all amendments); and
- buildings which are not intended to be occupied on a daily or full-time basis, including, but not limited to, automatic telephone exchanges, pump houses and substations.

GENERAL APPLICATION

All areas of newly designed or newly constructed facilities and altered portions of existing facilities shall comply with Sections 5.0 to 7.0 of this guideline, unless otherwise provided in this section or as modified in Section 8.0, Special Facilities and Areas.

Exceptions: The requirements of Sections 5.0 to 7.0 do not apply to the following:

- service rooms
- elevator machine rooms
- janitor rooms
- service spaces
- crawl spaces
- attic or roof spaces.

APPLICATION BASED ON FACILITY USE

The specific facility types listed in Section 8.0 shall, as well as complying with this document, fulfil the more stringent restrictions within additional design requirements specified in any other governing documents.

SECTION 8.0.

Where a facility contains more than one use covered by a special application section, each portion shall comply with the requirements for that section in addition to all other general provisions.

WORK AREAS AND EMPLOYEE-DESIGNATED AREAS

All facilities shall be accessible for employees, as well as patrons/users. All areas intended for use by employees shall be designed and constructed to comply with this guideline.

TEMPORARY FACILITIES

This guideline applies to temporary facilities, as well as permanent facilities.

RETROFITTING, ALTERATIONS AND ADDITIONS

Each addition to an existing facility shall be regarded as an *alteration*.

Each space or element added to the existing facility shall comply with the applicable provision(s) of this guideline.

Except where the provision of accessible features is deemed infeasible, no alteration shall decrease or have the effect of decreasing accessibility or usability of an existing facility to below the requirements for new construction at the time of alteration.

If existing elements, spaces or common areas are altered, then each such altered element/space/feature/area shall comply with all applicable provisions. If the applicable provision for new construction requires that an element/space/feature/area be on an accessible route and the altered element/space/feature/area is not on an accessible route, this route shall be altered to become accessible.

If alterations of single elements, when considered together, amount to an alteration of a room or space in a facility, the entire space shall be made accessible.

No alteration of an existing element, space or area of a facility shall impose a requirement for greater accessibility than that which would be required for new construction.

If an escalator or stairs are proposed as a means of access where none existed previously, and major structural modifications are necessary for such installations, then a means of accessible access shall also be provided.



Scope, Application, and Enforcement 3.0

If a planned alteration entails alterations to an entrance, and the facility has an accessible entrance, the entrance being altered is required to be accessible.

If the alteration work is limited solely to the electrical, mechanical or plumbing system, or to hazardous material abatement, or to automatic sprinkler retrofitting, and does not involve the alteration of any elements or spaces required to be accessible under these guidelines, then this guideline does not apply (except for alarms, public telephones and assistive listening systems).

An alteration that affects the usability of or access to an area containing a primary function shall be made to ensure that, to the maximum extent feasible, the path of travel to the altered area, the restrooms, telephones and drinking fountains serving the altered area are readily accessible to and usable by individuals with disabilities.

Where the provision of accessible features is deemed infeasible, and the guideline allows a reduction of manoeuvring space from the requirements for new construction, the reduced dimensions are minimums. Where possible, larger manoeuvring spaces must be provided.

HERITAGE FACILITIES

This guideline will generally apply to alterations to a Heritage Facility, however, under the Ontario Human Rights Code, there are allowances for modification to the defining features of a Heritage Facility, which are deemed to alter the essential nature or substantially affect the viability of the enterprise.

Public Heritage Facilities should be assessed for compliance to accessibility guidelines on an individual basis, to determine the most effective and least disruptive means of retrofit, where required. Consider the following general guidelines:

- Facilities and/or areas that are generally used independently by the public and have undergone extensive modernization should be permanently and fully accessible. This includes parking areas, reception areas, washrooms, food service areas and gift shops. It can also include walkways and garden areas. If accessibility is limited by non-heritage elements, those elements should be revised.

- Facilities and/or areas which are used only by guided tour groups, through which assistance could easily be provided to open doors or to place a temporary ramp, could remain as existing or with minor temporary modifications.
- It is desirable to provide a complete experience of a Public Heritage Facility. If an accessible area or areas can be provided to fully experience a given site or facility context, access to the entire site or facility is not necessary.
- Access to above- and below- grade areas is not necessary if the context of those areas can be adequately provided on the accessible floor level.

If retrofit for accessibility of a main public entrance in a Heritage Facility would substantially threaten or destroy the historic significance of the facility, access shall be provided at an alternative entrance with directional signs at the main public entrance. The accessible entrance should have a notification system (if not generally used by the public) and remote monitoring (if security is an issue).

Safe egress from a Heritage Facility is required.

ENFORCEMENT

In general, the City of Hamilton, through the project management function, shall ensure compliance to this Guideline during the pre-planning, design, construction documents preparation, and contract administration.





The previous version of this document (1994) has been fully incorporated into all City of Hamilton, procurement and contract documentation. Therefore, all documentation will be updated to reflect this new Guideline going forward.

The requirements contained in this Guideline are to be considered recommendations only, and cannot be imposed on buildings, except where they are specifically required in the Ontario Building Code. Construction or alterations in all City of Hamilton owned, operated, or leased facilities that are deemed open and accessible to the Public must meet the full extent of the requirements in this Guideline, unless it can be shown that a requirement cannot be reasonably complied with (see Definitions: infeasible or infeasibility).

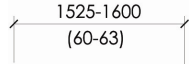

GRAPHIC CONVENTIONS

Dimensions that are not marked maximum or minimum are absolute, unless otherwise indicated. All dimensions are noted in mm and (in.) unless noted otherwise.

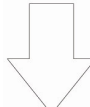
<u>CONVENTION</u>	<u>DESCRIPTION</u>
Dimension showing Metric units (in millimeters unless otherwise stated) above the line and Imperial Units (in inches unless otherwise stated) below the line in parentheses	
Dimension for small measurements	
Dimension showing a range with minimum - maximum	
Minimum	min
Maximum	max
A wall, floor, ceiling or other element cut in section or plan	
Direction of travel or approach	

GENERAL TERMINOLOGY

comply with: Meet one or more specification of this guideline.

if ... then: Denotes a specification that applies only when the conditions described are present.

may: Denotes an option or an alternative.

shall: Denotes a mandatory specification or requirement.

should: Denotes an advisory specification or recommendation.

DEFINITIONS

Access aisle: An accessible pedestrian space between elements, such as parking spaces, seating and desks that provides clearances appropriate for the use of the elements.

Accessible: Describes a site, building, facility, or portion thereof that complies with this guideline.

Accessible element: An element specified by this guideline (for example telephone, controls etc.).

Accessible route: A continuous unobstructed path connecting accessible elements and spaces of a facility. Interior accessible routes may include corridors, floors, ramps, elevators, platform lifts, and clear floor spaces, at fixtures. Exterior accessible routes may include parking access aisles, curb ramps, crosswalks, at vehicular ways, walks, ramps and platform lifts.

Accessible space: Space that complies with this guideline.

Adaptable: The ability of a certain building space or element, such as kitchen counters, sinks, and grab bars, to be added or altered so as to accommodate the needs of individuals with or without disabilities or to accommodate the needs of persons with different types or degrees of disabilities.

Addition: An expansion, extension, or increase in the gross floor area of a facility.

Alteration: A change to a facility that affects or could affect the usability of the facility or part thereof. Alterations include, but are not limited to, remodelling, renovation, retrofitting, rehabilitation, reconstruction, historic restoration, resurfacing of circulation paths or vehicular ways, changes or rearrangement of the structural parts or elements, and changes or rearrangement in the plan configuration of walls and full-height partitions. Normal maintenance, painting, or wallpapering, or changes to mechanical or electrical systems are not alterations, unless they affect the usability of the building.

Area of rescue assistance: An area which has direct access to an exit, where people who are unable to use stairs may remain temporarily in safety to await further instructions or assistance during emergency evacuation.

Assembly area: A room or space accommodating a group of individuals for recreational, educational, political, social, civic, or amusement purposes, or for the consumption of food and drink.

Attic or roof space: The space between the roof and the ceiling of the top storey or between a dwarf wall and a sloping roof.

Automatic door: A door equipped with a power-operated mechanism and controls that open and close the door automatically upon receipt of a momentary actuating signal. The switch that begins the automatic cycle may be a photoelectric device, floor mat, or manual switch. (See Power-assisted door)

Boardroom, or conference room or meeting room: Room used for meetings, which accommodates more than six people.

Building: A structure occupying an area greater than ten square metres, consisting of a wall, roof, and floor or any of them, or a structural system serving the function thereof, including all plumbing, fixtures and service systems appurtenant thereto; or a structure occupying an area of ten square meters or less that contains plumbing, including the plumbing appurtenant thereto; or structures designated in the Ontario Building Code.

Circulation Path: An exterior or interior way of passage from one place to another for pedestrians, including, but not limited to, walks, hallways, courtyards, stairways, and stair landings.

Clear: Unobstructed.

Clear floor space: The minimum unobstructed floor or ground space required to accommodate a single, stationary wheelchair, scooter or other mobility device, including the user.

Closed-circuit telephone: A telephone with dedicated line(s) such as a house phone, courtesy phone, or phone that must be used to gain entrance to a facility.

Common use: Refers to those interior and exterior rooms, spaces or elements that are made available for the use of a restricted group of people (for example, occupants of a homeless shelter, the occupants of an office building, or the guests of such occupants).

Cross slope: The slope that is perpendicular to the direction of travel (see running slope).

Curb ramp: A short ramp cutting through a curb or built up to a curb.

Detectable warning: A standardized surface feature built into or applied to walking surfaces or other elements to warn visually impaired people of hazards on a circulation path.

Disability: Any restriction or lack of ability to perform an activity in the manner or within the range considered normal for a human being.

Egress, Means of: A continuous and unobstructed way of exit travel from any point in a facility to a public way. A means of egress comprises vertical and horizontal travel and may include intervening room spaces, doorways, hallways, corridors, passageways, balconies, ramps, stairs, enclosures, lobbies, horizontal exits, courts and yards. An accessible means of egress is one that complies with this guideline and does not include stairs, steps or escalators. Areas of rescue assistance, protected lobbies or protected elevators may be included as part of an accessible means of egress.

Element: An architectural or mechanical component of a building, facility, space or site (e.g., telephone, curb ramp, door, drinking fountain, seating or water closet).

Entrance: Any access point to a building or portion of a facility used for the purposes of entering. An entrance includes the approach walk, the vertical access leading to the entrance platform, the entrance platform itself, vestibules (if provided), the entry door(s) or gate(s), and the hardware of the entry door(s) or gate(s).

Facility or facilities: All or any portion of buildings, structures, site improvements, complexes, equipment, roads, walks, passageways, parks, parking lots or other real or personal property located on a site.

Ground floor: Any occupiable floor less than one storey above or below grade with direct access to grade.

A facility always has at least one ground floor and may have more than one ground floor, as where a split-level entrance has been provided or where a facility is built into a hillside.

Heritage facility: Facility or portions thereof designated under the Ontario Heritage Act (See Public Heritage Facility)

Impairment: Any loss or abnormality of psychological, physiological or anatomical structure or function.

Infeasible or Infeasibility: Means, with respect to an alteration, building or facility, that it has little likelihood of being accomplished, due to one, or any combination of the following:

- existing structural conditions would require moving or altering a load-bearing member which is an essential part of the structural frame;
- other existing physical or site constraints prohibit the modification or addition of necessary elements, spaces or features which are in full and strict compliance with the minimum requirements for accessibility as set out in this document;
- it is determined that the proposed alteration cannot be modified to reflect this Guideline due to the limitation of project scope as defined by the project stakeholders at the onset of the project; or
- it is determined that the proposed alteration cannot be modified to reflect this Guideline due to pre-existing conditions present at the location of the proposed modification.



Mezzanine or **mezzanine floor**: That portion of a storey which is an intermediate floor level, placed within the storey and having occupiable space above and below its floor.

Marked crossing: A crosswalk or other identified path intended for pedestrian use in crossing a vehicular way.

Occupiable: A room or enclosed space designed for human occupancy in which individuals congregate for amusement, educational or similar purposes, or in which occupants are engaged at labour, and which is equipped with means of egress, light and ventilation.

Private open space: Privately owned land areas within a subdivision, generally smaller in scale than open space, which have been left free from structures, parking lots and roads. These types of areas generally benefit only the residents or employees of the particular subdivision and usually remain in private ownership.

Open space: Large-scale tracts of land without visible evidence of residential, commercial or industrial development. These areas may be privately or publicly owned and are generally left in a natural state and not programmed for active recreation. The benefits of open lands typically extend beyond the immediate area and usually provide community-wide benefits.

Operable portion: A part of a piece of equipment or appliance used to insert or withdraw objects, or to activate, deactivate, or adjust the equipment or appliance (for example, coin slot, push button, handle).

Park: Land that is privately or publicly held that has been developed for multiple recreational and leisure-time uses. This land benefits the entire community and balances the demands of the public for outdoor recreational facilities and other amenities, such as pathways, plazas, picnic areas, playgrounds, water features, spaces for free play and leisure.

Power-assisted door: A door used for human passage that has a mechanism that helps to open the door or relieves the opening resistance of a door, upon the activation of a switch or a continued force applied to the door itself.

Public Sector: For the purposes of this document only, this includes any person employed, residing, visiting, or accessing any public space within the boundaries of the City of Hamilton.

Public Heritage Facility: A facility designated under the Ontario Heritage Act that is open and accessible to the public. (See Heritage Facility)

Public use: Describes interior or exterior rooms or spaces that are made available to the general public. Public use may be provided at a facility that is privately or publicly owned.

Ramp: A walking surface, which has a running slope greater than 1: 25.

Running slope: The slope that is parallel to the direction of travel. (See Cross slope)

Semi public spaces: An area that is contained on private property, but becomes a continuation of the community fabric by virtue of its use by the pedestrian public (e.g., malls, campuses).

Service entrance: An entrance intended primarily for delivery of goods or services and not intended for use by the public.

Service room: A room provided in a building to contain equipment associated with building services.

Service space: A space provided in a facility to facilitate or conceal the installation of facility service facilities such as chutes, ducts, pipes, shafts or wires.

Shore lines: Bands of contrasting colour and/or texture used to delineate an area (e.g., a clearway) or define the edge of a curb.

Signage: Displayed verbal, symbolic, tactile and pictorial information.

Site: A parcel of land bound by a property line or a designated portion of a public right-of-way.

Site improvement: Landscaping, paving for pedestrian and vehicular ways, outdoor lighting, and recreational facilities added to a site.

Sleeping accommodations: Rooms in which people sleep, for example, a dormitory.

Space: A definable area (e.g., room, toilet room, hall, assembly area, entrance, storage room, alcove, courtyard or lobby).

Storey: That portion of a building included between the upper surface of a floor and the upper surface of the floor next above. If such portion of a building does not include occupiable space, it is not considered a storey for the purposes of this guideline. There may be more than one floor level within a storey, as in the case of a mezzanine or mezzanines.

Structural frame: The columns and the girders, beams, trusses and spandrels having direct connection to the columns and all other members which are essential to the stability of the building as a whole.

TDD: (Telecommunication Device for the Deaf): See Text telephone.

TTY: (Teletypewriter): See Text telephone.

Tactile: Describes an object that can be perceived using the sense of touch.

Temporary structure: A facility that is not of permanent construction but that is extensively used, or is essential for public use for a period of time. Examples of temporary facilities covered by this guideline include, but are not limited to, viewing stands, bleacher areas, temporary kiosks, temporary health screening services or temporary safe pedestrian passageways around a construction site. Structures and equipment directly associated with the actual processes of construction, such as scaffolding, bridging, materials hoists, or construction trailers, are not included.

Text telephone (TTY): Machinery or equipment that employs interactive text-based communication through the transmission of coded signals across the guideline telephone network. Text telephones can include, for example, devices known as TDDs (telecommunication display devices or telecommunication devices for deaf persons) or computers with special modems. Text telephones are also called TTYs, an abbreviation for teletypewriter.

Urban Braille: A leading edge, user driven approach to planning and design of public spaces. It is a system of tactile information serving the needs of the visually impaired. By utilizing both colour and texture contrast it provides warning signals and clues related to orientation. Any reference to Urban Braille used in this Guideline is strictly for reference purposes only and does not supersede the current Urban Braille System prepared and utilized by the City of Hamilton.

Vehicular way: A route intended for vehicular traffic, such as a street, driveway or parking lot, within the boundary of the site.

Walk: An exterior pathway with a prepared surface intended for pedestrian use, including general pedestrian areas, such as plazas and courts, within the boundary of the site.



All areas of newly designed or newly constructed facilities and altered portions of existing facilities shall comply with this section, unless otherwise provided in section 5.0 Physical Accessibility or as accepted below.

The requirements of this section apply to all facilities except

- residential occupancies;
- buildings of Group F Division 1 occupancy, as defined by the Ontario Building Code (latest edition with all amendments); and
- buildings which are not intended to be occupied on a daily or fulltime basis, including, but not limited to, automatic telephone exchanges, pump houses and substations.

The requirements of this section apply to all areas of a facility except:

- service rooms
- elevator machine rooms
- janitor rooms
- service spaces
- crawl spaces
- attic or roof spaces

To facilitate ease of reference, specific design requirements have been categorized as follows:

5.0 Physical Accessibility



6.0 Visual Accessibility



7.0 Audible Accessibility



8.0 Special Facilities and Areas Accessibility

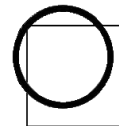



Sub-sections

- 5.1 **Access and Circulation**
– e.g., pathways, ramps, elevators, etc.
- 5.2 **Washroom Facilities**
– e.g., lavatory heights, washroom stalls, etc.
- 5.3 **Amenities**
– e.g., public telephone, furniture, etc.
- 5.4 **Systems and Controls**
– e.g., Emergency exits, areas of rescue assistance, etc.



Historically our buildings have been designed for the able bodied adult, however with technological and cultural advancements we have recognised the need for universal access.

We now recognise and have to plan for the changing variety of physical aids and conditions, and provide for their spatial and ergonomic impact.

This section deals with the design, and provision of requirements for physical access to spaces by all persons, notwithstanding their physical condition.

5.1.

- 1 Space and Reach Requirements
- 2 Ground and Floor Surfaces
- 3 Protruding Objects
- 4 Accessible Routes, Paths and Corridors
- 5 Exterior Pedestrian Routes
- 6 Vehicular Access
- 7 Signals at Crosswalks
- 8 Entrances
- 9 Doors
- 10 Gates, Turnstiles and Openings
- 11 Interior Routes
- 12 Ramps
- 13 Stairs
- 14 Handrails
- 15 Escalators
- 16 Elevators
- 17 Platform Lift



Barriers and Obstacles

Our buildings have historically been designed only for the able bodied adult. The invention of the wheelchair redefined the circulation requirements. Accordingly, Building Codes have adapted and been modified to accommodate the requirements of an average user in an average wheelchair.

Technological advances have since brought us the electric wheelchair and the motorised scooter; while cultural advances have allowed people with various forms of disabilities to become more active participants in our society. The Ontario Building Code minimum requirements do not allow for this inclusiveness, and herein.

Design Requirements

Space and reach range provisions for persons who use wheelchairs, scooters and other mobility devices shall comply with the following:

- 1) Required space for a wheelchair to make a 360° turn: 1930 mm (6 ft. 4 in.) - **Figure 5.1.1(a).**
- 2) Required minimum clear floor or ground space required to accommodate a single, stationary wheelchair or scooter and occupant: 760 mm x 1370 mm (30 in. x 54 in.) - **Figures 5.1.1(b) and 5.1.1(c).**
- 3) The minimum clear floor or ground space for wheelchairs or scooters may be positioned for forward or parallel approach to an object.
- 4) Clear floor or ground space for wheelchairs may be part of the knee space required under some objects.

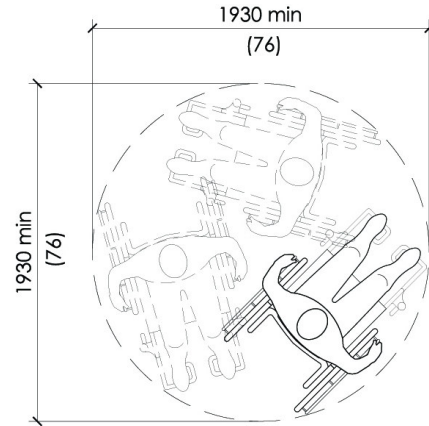

Figure 5.1.1(a)
360° Turning Space

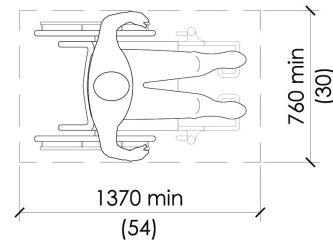

Figure 5.1.1(b)
Clear Floor Space for Wheelchair

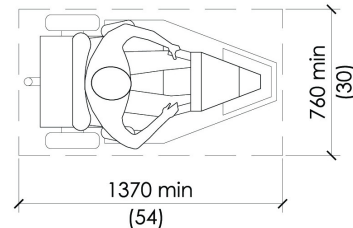

Figure 5.1.1(c)
Clear Floor Space for Scooter



- 5) One full, unobstructed side of the clear floor or ground space for a wheelchair or scooter shall adjoin or overlap an accessible route or adjoin another wheelchair clear floor space. If a clear space is located in an alcove or otherwise confined on all or part of three sides, additional manoeuvring clearances shall be provided - **Figures 5.1.1(d), 5.1.1(e), 5.1.1(f) and 5.1.1(g)**.

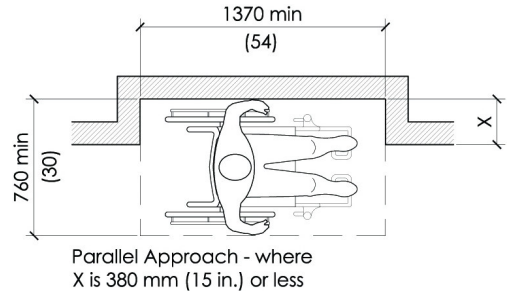

Figure 5.1.1(d)
Clearances at Alcove

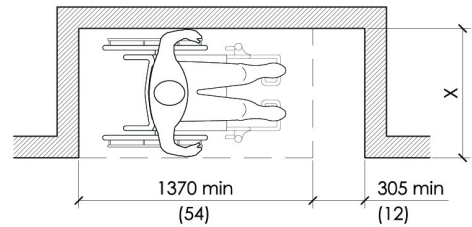
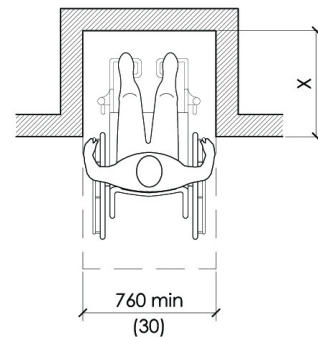
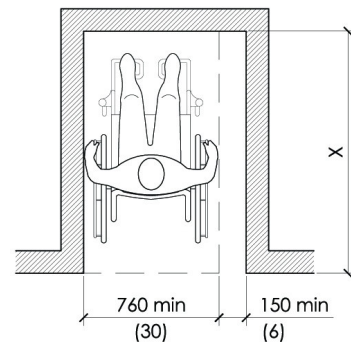

Figure 5.1.1(e)
Clearances at Alcove



Frontal Approach - where
X is 610 mm (24 in.) or less

Figure 5.1.1(f)
Clearances at Alcove



Frontal Approach - where X is
more than 610 mm (24 in.)

Figure 5.1.1(g)
Clearances at Alcove



- 6) Surface of clear floor spaces for wheelchairs and scooters shall comply with section 5.1.2 *Ground and Floor Surfaces*.
- a) If the clear floor space only allows forward approach to an object:
- i) the maximum high forward reach allowed shall be 1220 mm (48 in.); and
 - ii) the minimum low forward reach is 400 mm (15-3/4 in.) - **Figure 5.1.1(h)**.
- b) If the high forward reach is over an obstruction, reach and clearances shall be as shown in - **Figure 5.1.1(i)**.

NOTE: In **Figure 5.1.1(i)**

X shall be less than or equal to 635 mm (25 in.); Z shall be greater than or equal to X.
When X is less than 510 mm (20 in.), then Y shall be 1220 mm (48 in.) maximum.
When X is 510 mm (20 in.) to 635 mm (25 in.) then Y shall be 1120 mm (44 in.) maximum

- c) If the side reach is over an obstruction, the reach and clearances shall be as shown in - **Figures 5.1.1(j)**.

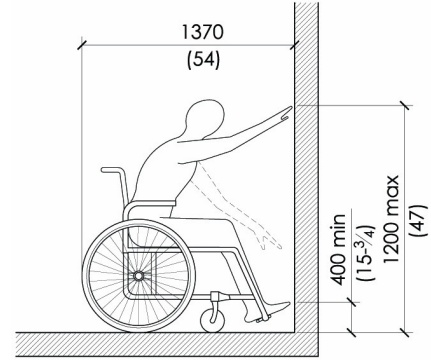

Figure 5.1.1(h)
Forward Reach

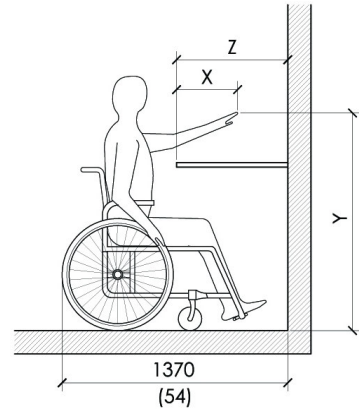

Figure 5.1.1(i)
Forward Reach over an Obstruction (Refer to Note for measurements)

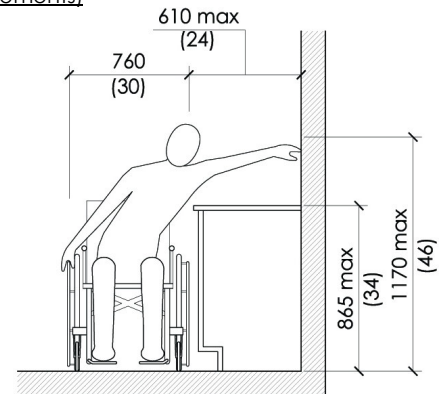

Figure 5.1.1(j)
Side Reach – Maximum Distance to Wheelchair



- d) If the clear floor space allows parallel approach to an object:
 - i) the maximum high side reach is 1370 mm (54 in.); and
 - ii) the minimum low side reach is 230 mm (9 in.) above the floor
- **Figure 5.1.1(k).**
- e) Notwithstanding these requirements, the Ontario Building Code requires all controls for the operation of facility services or safety devices, including electrical switches, thermostats and intercom switches, be mounted at not more than 1220 mm (48 in.) above the floor.

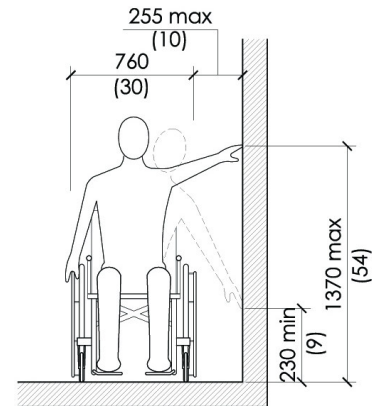

Figure 5.1.1(k)
Side Reach



Barriers and Obstacles

For seniors, young children, and people with physical and visual impairments; small and uneven changes in floor level; irregular floor surfaces (e.g., cobblestone or pea-gravel) and thick pile carpeting can be difficult.

For people with visual impairments, glare from polished floor surfaces is a particular obstacle. It can obscure important orientation and safety features, and cause people to be unsure of the location of the ground.

In addition, heavily patterned floors can create visual confusion.

Design Requirements

- 1) Ground and floor surfaces shall be stable, firm, slip-resistant and glare-free.
- 2) Changes in level, except for elevators and other elevating devices shall conform to **Table 5.1.2** and **Figure 5.1.2(a)** and be provided with a high contrast strip to assist people with visual impairments.
- 3) Carpets or carpet tile shall:
 - a) be securely fixed;
 - b) have a firm cushion, pad or backing, where used;
 - c) have a level loop, textured loop, level cut pile, or level cut/uncut pile texture with a maximum pad and pile height of 13 mm (1/2 in.); and
 - d) have exposed edges fastened to floor surfaces with trim conforming to **Table 5.1.2**.
- 4) Gratings located in walking surfaces shall:
 - a) have spaces not greater than 13 mm (1/2 in.) wide in one direction;
 - b) be placed so that the long dimension is perpendicular to the dominant direction of travel - **Figures 5.1.2(b)** and **5.1.2(c)**; and
 - c) where possible, minimise the length of spaces.

Related Sections

- 5.1.4 Accessible Routes, Paths and Corridors
- 6.3 Materials and Finishes
- 6.4 Texture and Colour
- 6.8 Detectable Warning Surfaces

Vertical Rise	Edge Treatment
0 to 6 mm (0 - ¼ in.)	May be vertical
6.1 mm to 13 mm (¼ in. - ½ in.)	Bevel, maximum slope 1:2
over 13 mm (over ½ in.)	Treat as a sloped floor, ramp or curb ramp

Table 5.1.2
Changes in Level

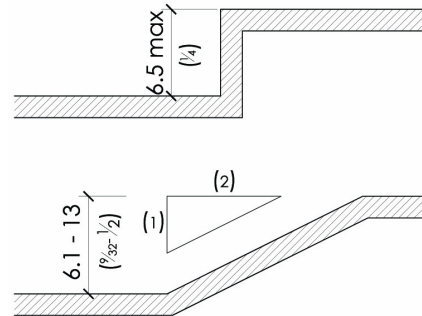

Figure 5.1.2(a)
Changes in Level

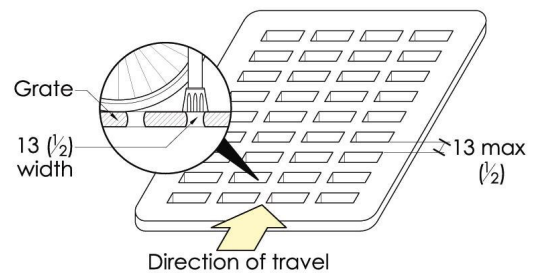

Figure 5.1.2(b)
Grills and Gratings

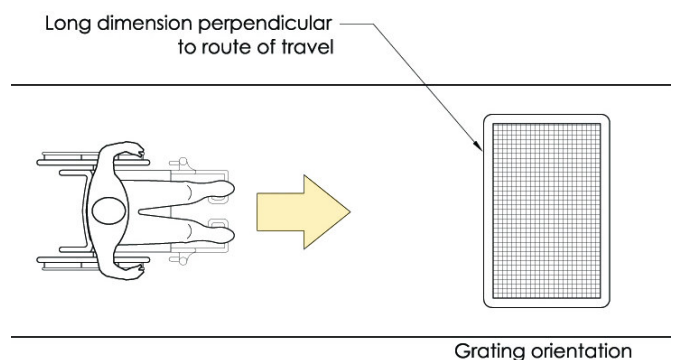

Figure 5.1.2(c)
Grills and Gratings



Barriers and Obstacles

Pathways are to be clear of any obstacles in order to provide universal accessibility and general safety.

A protruding object that is above the detection range of a cane, can be hazardous not only to someone with visual impairments, but can also cause injury to a person who is distracted.

Design Requirements

- 1) Objects protruding from walls with their leading edges between 680 mm and 2100 mm (26-3/4 in. and 82-3/4 in.) from the floor shall protrude not more than 100 mm (4 in.) into pedestrian areas, such as walkways, halls, corridors, passageways or aisles - **Figures 5.1.3(a) and 5.1.3(b).**
- 2) Objects attached to a wall with their leading edges at or below 680 mm (26-3/4 in.) from the floor may protrude any amount - **Figure 5.1.3(c).**
- 3) Freestanding objects shall not have any overhang of more than 305 mm (12 in.) between 680 mm and 2100 mm (26-3/4 in. and 82-3/4 in.) from the ground or floor.
- 4) The maximum height of the bottom edge of freestanding objects with a space of more than 305 mm (12 in.) between supports shall be 680 mm (26-3/4 in.) from the ground or floor.
- 5) Protruding objects shall not reduce the clear width required for an accessible route or manoeuvring space - **Figure 5.1.3(c)**

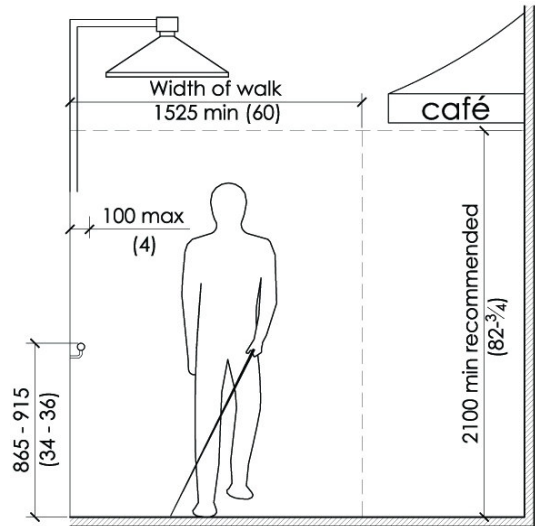

Figure 5.1.3(a)
Limits of Protruding Objects

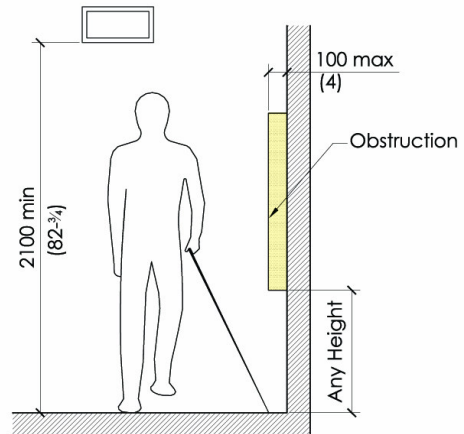

Figure 5.1.3(b)
Limits of Protruding Objects

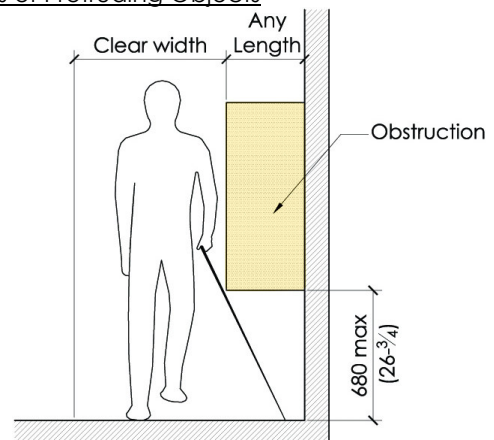

Figure 5.1.3(c)
Limits of Protruding Objects



- 6) The minimum clear headroom in pedestrian areas, such as walkways, halls, corridors, passageways, or aisles, shall be 2100 mm (82-3/4 in.) - **Figure 5.1.3(d).**
- 7) A detectable guard, a guardrail or other barrier having its leading edge at or below 680 mm (26-3/4 in.) from the floor shall be provided where the headroom of an area adjoining an accessible route is reduced to less than 2100 mm (82-3/4 in.) - **Figure 5.1.3(d).**

Related Sections

- 5.1.4 Accessible Routes, Paths and Corridors
- 6.3 Materials and finishes
- 6.4 Texture and Colour
- 6.8 Detectable Warning Surfaces

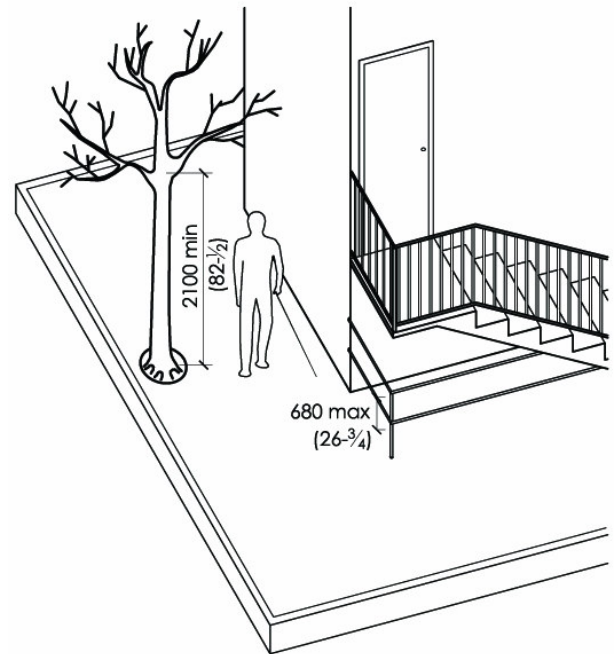

Figure 5.1.3(d)
Overhead Obstructions



Barriers and Obstacles

An accessible route of travel throughout a facility or an accessible site is required to maintain universal access. Consideration should be given to the size and ergonomic use of the wide variety of physical aids (e.g., wheelchairs, scooters, canes and crutches).

Consideration should also be given to the contrast of colours and light, and changes in texture, as these also delineate a clear route for persons with visual impairments.

Design Requirements

- 1) Wherever possible, all routes, paths or corridors shall comply with this section.
- 2) Accessible routes shall comply with this section.
- 3) Within a given site, at least one accessible route shall be provided to an accessible entrance as per section 5.1.8 Entrances.
- 4) An accessible route shall interconnect all accessible entrances, all accessible spaces and accessible elements within a facility, except where such a route would be hazardous.
- 5) An accessible route shall be provided within all occupiable floor areas, except to:
 - a) service rooms;
 - b) elevator machine rooms;
 - c) janitor rooms;
 - d) service spaces;
 - e) crawl spaces;
 - f) attic or roof spaces;
 - g) high-hazard industrial occupancies within portions of a floor area;
 - h) assembly occupancies with fixed seats where these portions are not part of an accessible route to spaces designated for wheelchair use; or
 - i) within a suite of residential occupancy.

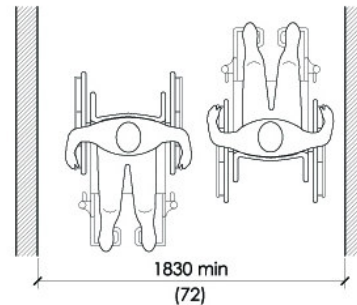
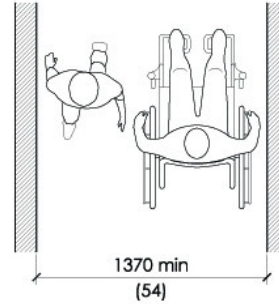
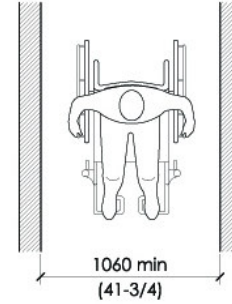

Figure 5.1.4(a)
Access Widths

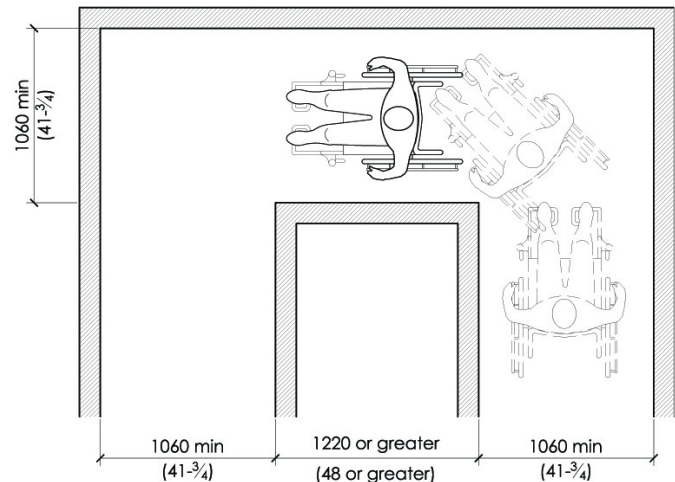

Figure 5.1.4.b
Turn around an Obstacle



- 6) Accessible routes are permitted to include ramps, curb ramps, stairs, elevators or other elevating devices (as permitted in section 5.1.17 *Platform Lifts*) where there exists a difference in elevation.
- 7) The minimum clear width of accessible routes shall be 1060 mm (41-3/4 in.) - **Figures 5.1.4(a)** and **5.1.4(b)**, except:
 - a) at doors, it shall be 950 mm (37-1/2 in.);
 - b) where additional manoeuvring space is required at doorways (See section 5.1.9 *Doors*);
 - c) at U-turns around obstacles less than 1220 mm (48 in.) wide, it shall be 1220 mm (48 in.) - **Figure 5.1.4(c)**;
 - d) for exterior routes, it shall be 1220 mm (48 in.); and
 - e) where space is required for two wheelchairs to pass, it shall be 1830 mm (72 in.) - **Figure 5.1.4(a)**.
- 8) Accessible routes shall
 - a) have a running slope not steeper than 1:20; and
 - b) have a cross slope not steeper than 1:50.
- 9) Every accessible route less than 1830 mm (72 in.) wide shall be provided with an unobstructed space of not less than 1830 mm (72 in.) in width and 1830 mm (72 in.) in length, located not more than 30 m (98 ft. 5 in.) apart.
- 10) Except at stairs and at elevated platforms such as performance areas or loading docks, where the edges of accessible routes, paths or corridors are not level with the adjacent surface, they shall be protected by:
 - a) a colour contrasting curb at least 75 mm (3 in.) high, where the change in level is more than 200 mm to 610 mm (8 in. to 24 in.) below the route, path or corridor - **Figure 5.1.4.d**; and
 - b) a guard which meets the requirements listed in section 5.1.12 *Ramps* where the change in level is greater than 610 mm (24 in.).

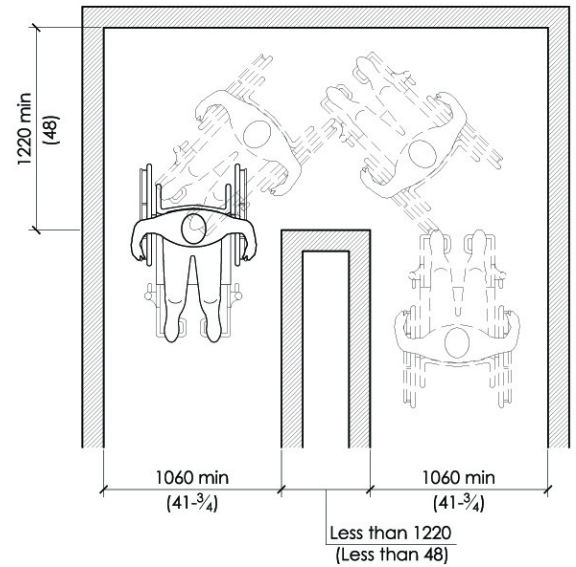

Figure 5.1.4(c)
Turn around an Obstacle

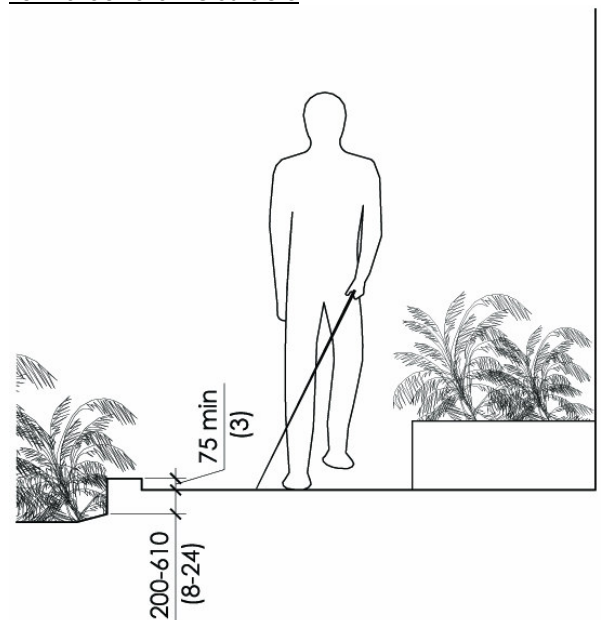

Figure 5.1.4(d)
Edge Protection



- 11) Where there is a change in direction along an accessible route and the intended destination of the route is not evident, directional signage and/or detectable warning surfaces shall be provided.
- 12) All portions of accessible routes shall be equipped to provide a level of illumination of at least 50 lux (4.6 ft-candles).

Exception: Outdoor park settings where routes are not normally illuminated.

Related Sections

- 5.1.2 Ground and Floor Surfaces
- 5.1.5.6 Snow Accumulation and Removal
- 5.1.11 Interior Routes
- 5.2.1 Glare and Light Sources
- 5.2.2 Lighting
- 5.2.3 Materials and Finishes
- 5.2.4 Texture and Colour
- 5.2.7 Signage and Wayfinding
- 5.2.8 Detectable Warning Surfaces





Barriers and Obstacles

Provision of universal access within a controlled environment, such as a building, becomes a heightened task when faced with providing such access outside. Additional factors now have to be considered such as vehicles, weather, animals, natural obstacles etc.

Provisions for the following have been considered:

- Crosswalks;
- Curb ramps/curb cuts on public right of way;
- Grades and elevation changes;
- Pedestrian routes: paths, sidewalks and walkways;
- Traffic islands on public right of way; and
- Snow accumulation and removal.

Design Requirements

- 1) Wherever possible, **crosswalks** shall:
 - a) be located at right angles to the sidewalk;
 - b) be free of obstacles (e.g., signal supports, garbage bins, mailboxes, etc.) (See section 5.1.7 *Signals at Crosswalks*);
 - c) have suitable curb ramps at each end of the crosswalk or where level differences of 19 mm (3/4 in.) or more occur - **Figure 5.1.5(a)**;
 - d) have a minimum width of 3000 mm (9 ft. 10 in.) - **Figure 5.1.5(b)**;
 - e) be clearly marked by 100 mm (4 in.) white painted lines or by using distinctive highly contrasting paving materials;
 - f) not contain manhole covers, storm gratings or other obstacles that limit free movement and where catch basins are necessary they should be positioned wherever possible on the upstream side of the crosswalk;
 - g) where located between intersections:
 - i) have suitable curb ramps (See section 5.1.5.2 *Exterior Pedestrian Routes – Curb Ramps/Curb Cuts on Public Right of Way*);
 - ii) be located in clear view of oncoming traffic in all directions;
 - iii) clearly indicate a point for vehicles to stop at a sufficient and safe distance from the crosswalk;
 - iv) be a sufficient distance from the intersection to permit a safe crossing;

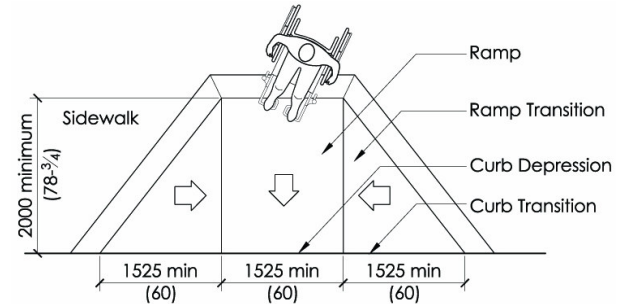

Figure 5.1.5(a)
Curb ramp

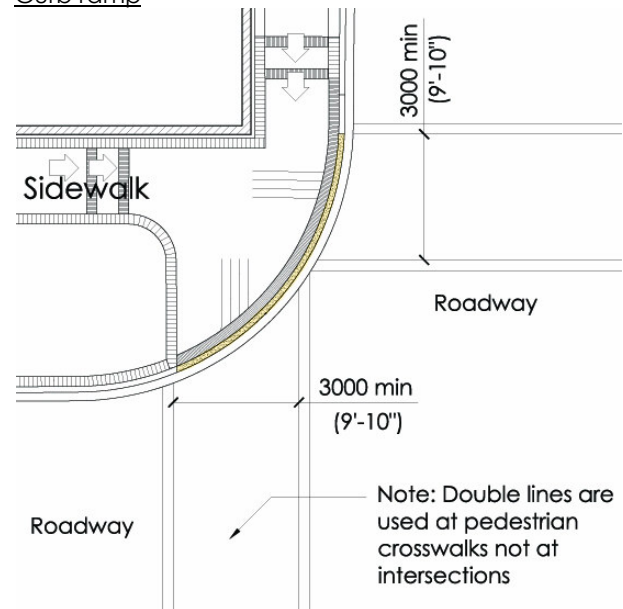

Figure 5.1.5(b)
Curb ramp at Crosswalk



- h) have a yellow strip at the edge of the sidewalk/curb ramp and the road surface.
 - i) where “pedestrian activated crossovers” are provided:
 - i) push buttons (or any other type of activation device) shall be clearly identifiable - **Figure 5.1.5(c)**;
 - ii) be adjacent to the crosswalk;
 - iii) be mounted on a nearby post at a height of 1065 mm (42 in.); and paving at the post shall have a level and clear area of 915 mm x 1220 mm (36 in. x 48 in.); and
 - j) where a traffic island is incorporated - be provided with appropriate curb ramps and markings **Figure 5.1.5(c)**.
- 2) Wherever possible curb ramps/curb cuts on public right of way shall:
- a) be provided wherever there is a level change between the pedestrian route and the road surface at all street corners and where crosswalks are provided where the pedestrian path is protected from motorists by a stop sign or signal - **Figure 5.1.5(c)**;
 - b) have a minimum length of 2000 mm (78-3/4 in.) for safer sidewalk ramp transition - **Figure 5.1.5(a)**;
 - c) have a minimum width of 1525 mm (60 in.) when the curb ramp is located on a public thoroughfare – **Figure 5.1.5(d)**;
 - d) have flared non-slip sides;
 - e) be at right angles to the path of travel;
 - f) be of a clearly different and cane detectable texture (e.g., 13 mm (1/2 in.) deep incised lines at 100 mm (4 in.) on centre);
 - g) have the lower edge finished with a cane detectable rounded edge of 13mm (1/2 in.) in height;
 - h) have the lower edge marked with a yellow band at the edge of the road surface;
 - i) be located so that they are generally free of accumulated rainwater or melting snow;
 - j) be free and clear of obstacles (See Section 5.3.1 *Street Furniture*); and
 - k) have a clear and level landing of 1065 mm to 1525 mm (42 in. to 60 in.) at the top of the ramp to allow for the manoeuvring of mobility aids.

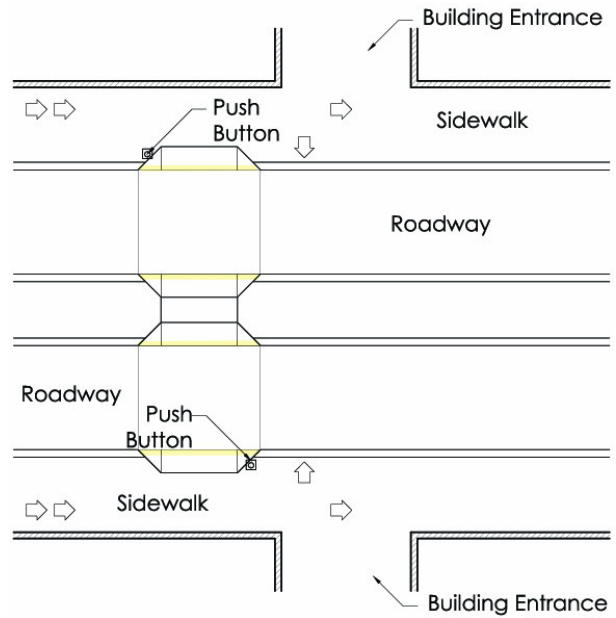

Figure 5.1.5(c)
Signals at Crosswalks

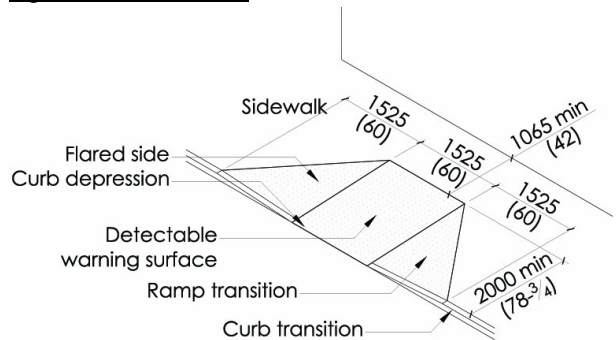

Figure 5.1.5(d)
Curb ramp



3) Grades and Elevation Changes:

- a) shall, whenever possible, not exceed a 1:20 slope on pedestrian routes;
- b) shall, whenever possible, be minimised in order to maintain a level path of travel;
- c) shall provide accessible ramps close to where an elevation change of 1:20 or greater may not be avoided;
- d) where unavoidable, exterior stairs should conform as much as possible to section 5.1.13 *Stairs*;
- e) occurring at landscaped areas sloped at 3:1 (horizontal to vertical) or more, adjacent to pedestrian routes, shall have a clear boundary of 150 mm (6 in.) minimum in height to aid persons with visual impairments - **Figures 5.1.5(e) and 5.1.5(f)**;
- f) greater than 460 mm (18 in.) that are adjacent to pedestrian routes should be provided with a handrail/guardrail - **Figure 5.1.5(g)** and section 5.1.14 *Handrails*.

4) Pedestrian Routes: Paths, Sidewalks and Walkways

- a) Public pedestrian routes shall be designed for universal access. All active pedestrian routes wherever possible shall be:
 - i) a minimum of 1525 mm (60 in.) wide (1650 mm (65 in.) preferred width); and
 - ii) free of protruding obstacles such as overhanging signs, branches, etc. - (See section 5.1.3 *Protruding Objects*)
- b) Exterior pedestrian entrance routes in a public right of way shall conform to 5.1.8.1 *Entrances - Accessible Routes to Entrances*.
- c) Where possible, pedestrian routes shall:
 - i) be 1100 mm (43-1/4 in.) minimum and widened to 1600 mm (63 in.) minimum at 30 m (98 ft. 5 in.) intervals when on private property to accommodate persons using mobility aids;

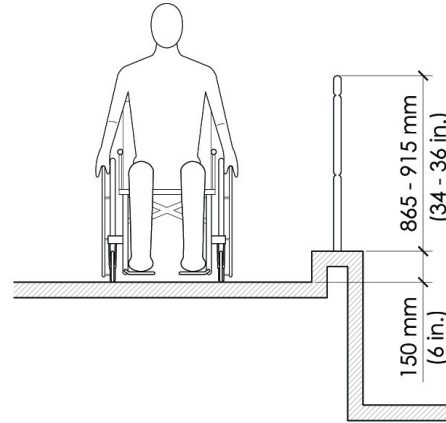

Figure 5.1.5(e)
Elevation Changes

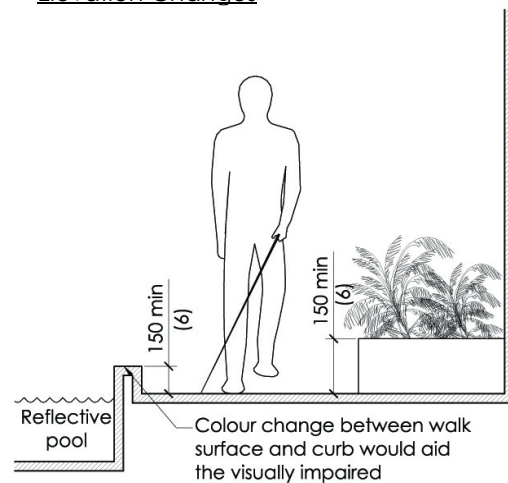

Figure 5.1.5(f)
Walkways with Landscaped Areas

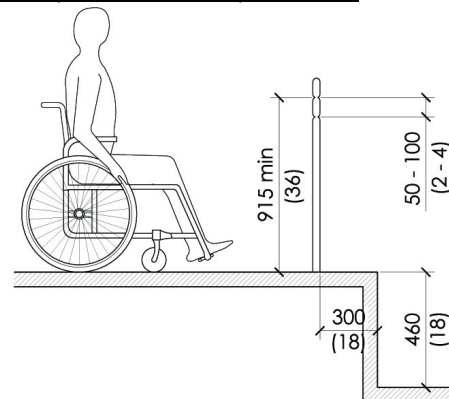

Figure 5.1.5(g)
Elevation Change greater than 460 mm (18 in.)



- ii) be constructed with firm and levelled unit paving with joints no greater than 6 mm (1/4 in.) wide - **Figure 5.1.5(h)**;
 - iii) be constructed with grating where water accumulation is a problem. The grating shall not have any openings wider than 13 mm (1/2 in.) and the smaller dimension of the grate shall be perpendicular to the path of travel (See section 5.1.2 *Ground and Floor Surfaces*);
 - iv) be provided with a 610 mm (24 in.) wide minimum amenity strip directly adjacent to the route (to accommodate vending machines, mailboxes, trees, etc.) This amenity strip shall be separated from the pedestrian route by a shore line; and
 - v) not be crossed or coincide with emergency vehicular routes.
- 5) **Traffic Islands on Public Right of Way:**
- a) should be built with materials and finishes that are easily distinguishable from the surrounding paving;
 - b) shall be at least 2500 mm (98-1/2 in.) wide to provide persons using mobility aids and seniors with a safe resting zone - **Figure 5.1.5(i)**; and
 - c) which are incorporated into a cross walk shall:
 - i) include appropriate curb ramps at each end in the area of the crosswalk;
 - ii) be level with the street pavement; and
 - iii) be clear of obstacles as per section 5.1.5.1(d) *Exterior Pedestrian Routes – Crosswalks*.
- 6) **Snow Accumulation and Removal:**
- Snow and ice accumulation and/or drifting snow are major problems for persons using mobility aids or persons with physical limitations and it drastically impedes their independence during the winter months.
- a) At entrance canopies or at accessible entrances, use radiant heating to automatically clear ice and snow, where timely maintenance and snow clearing may be problematic.

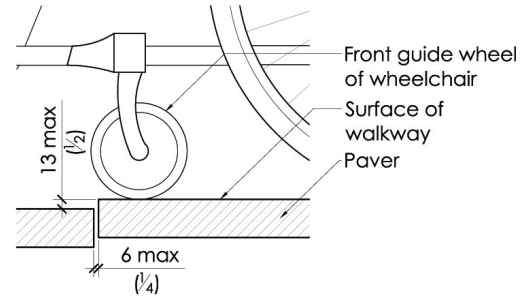

Figure 5.1.5(h)
Unit Pavement Joints

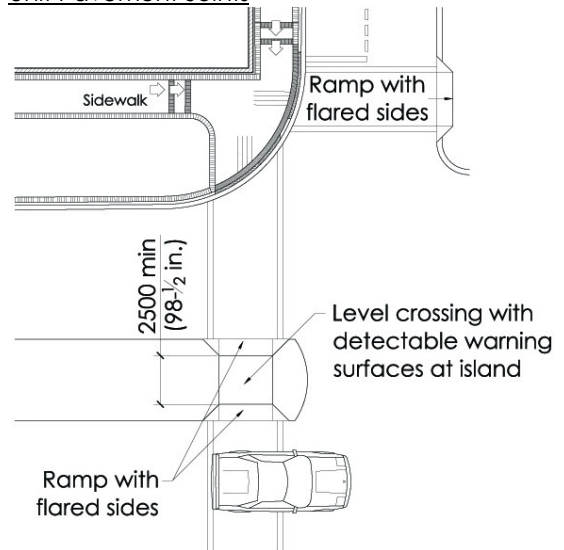

Figure 5.1.5(i)
Traffic Islands on Public Right of Way



- b) Where possible, remove snow to expose edges of the sidewalk at the curb to avoid mobility aids catching the edge and rolling.
- c) Regularly used pedestrian routes from the site boundary to the main entrance should be kept clear of snow and ice.
- d) Regularly used pedestrian routes from the site boundary to public transportation stops, taxi stands and curb cuts should be kept clear of snow and ice.
- e) Provide and plan for designated areas for snow piling.

Related Sections

- 5.1.8 Entrances
- 5.1.12 Ramps
- 5.1.13 Stairs
- 5.1.14 Handrails
- 5.3.1 Street Furniture
- 6.5 Urban Braille





Barriers and Obstacles

In as much as provisions are made for universal access to a facility, we should also consider access through the community via the private motorcar. (For public transportation, refer to 8.17 Transit Facilities)

Provisions for the following have been considered:

- Parking
- Passenger pick-up/drop-off areas

Design Requirements

- 1) **Parking**- number and location of designated spaces
 - a) Designated parking spaces shall be provided as a part of the shortest accessible route to the main accessible entrance, but no further than 30 m (98 ft. 5 in.).
 - b) Provide an accessible route from designated parking spaces to all accessible entrances (See section 5.1.8 Entrances).
 - i) In separate parking structures or lots that do not serve a particular building, designated parking spaces should be located on the shortest possible circulation route to an accessible pedestrian entrance of the parking facility.
 - ii) the accessible route should not require people to pass behind vehicles that may be backing out.
 - c) Provide 4 accessible parking spaces for the first 100 parking spaces (1:25)
 - i) provide 1 accessible parking space for each additional 50 parking spaces (1:50)
 - ii) provide 1 accessible parking space where 25 (or less) parking spaces occur.
 - d) In multi-storey or underground parking garages, at least one level of parking should include designated parking spaces, with signage clearly indicating level and route. Provision of designated parking space(s) at each level is preferred.

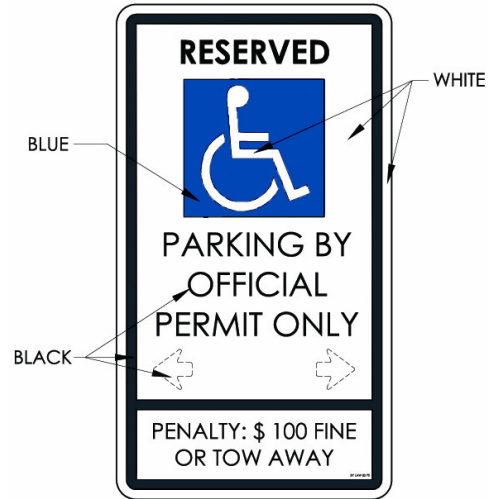

Figure 5.1.6(a)
Acceptable Vertical Parking Sign

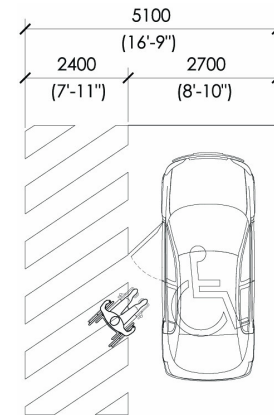

Figure 5.1.6(b)
Vertical Single Space Designated Parking



- 2) At designated parking spaces provide the following with regard to signage:
 - a) The International Symbol of Access painted on the pavement of the stall. Symbol of access on the pavement shall be:
 - i) at least 1000 mm (3 ft. 4 in.) long
 - ii) located at the centre of the stall
 - iii) in white painted on a background filed of blue.
 - b) Official designated disabled parking space sign - **Figure 5.1.6(a)** developed by the Ministry of Transportation (1991) mounted vertically. Vertical signs shall be
 - i) at least 450 mm (18 in.) x 750 mm (30 in.) and
 - ii) be installed at a height of 2100 mm to 2200 mm (7 ft. 0 in. to 7 ft. 4 in.) from the ground/floor surface to the bottom of the sign.
 - c) Where the location of the designated parking spaces is not clear or obvious, provide directional signs along the route leading to them.
- 3) Designated stalls shall:
 - a) measure 2700 mm (8 ft. 10 in.) wide with an adjacent aisle of at least 2400 mm (7 ft. 11 in.)
 - b) have a stable, firm and slip resistant surface
 - c) the access aisle shall have diagonal markings
 - d) have a height clearance of 2750 mm (9 ft. 0 in.) minimum but 2900 mm (9 ft. 6 in.) is preferred – **Figures 5.1.6(b), (c), (d)** and **(e)**.
- 4) Provide a suitable curb ramp from the accessible parking area to any adjacent sidewalk or pedestrian area where the difference in elevation is greater than 13 mm (1/2 in.) – **Figures 5.1.6(c), (d)** and **(e)**.
- 5) Where covered or underground parking spaces for cars are provided, all access and exit routes, including ramps serving such spaces, should have clear headroom of 2100 mm (6 ft. 9 in.) below beams, pipes, or sprinkler heads, however 2285 mm (7 ft. 6 in.) is recommended.
- 6) Parking meters are to be accessible for persons with disabilities - **Figures 5.1.6(e)** (See section 5.1.1 Space and Reach Requirements).
- 7) Provide clearly marked and safe pedestrian walkways.
- 8) Passenger pick-up/drop-off areas
 - a) Shall be located on the shortest possible circulation route to an accessible entrance, preferably the main entrance.

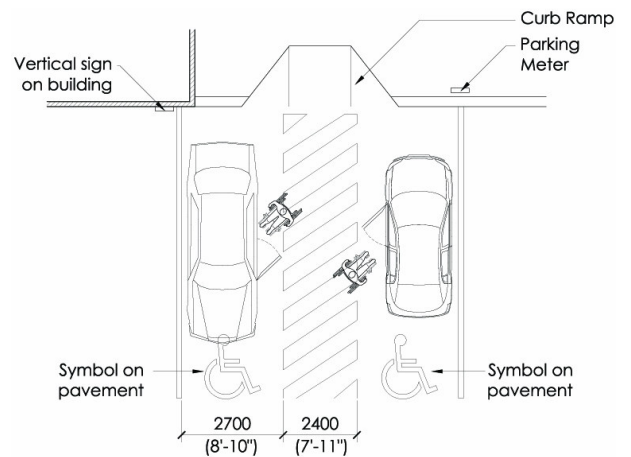

Figure 5.1.6(c)
Vertical Multi Space Designated Parking

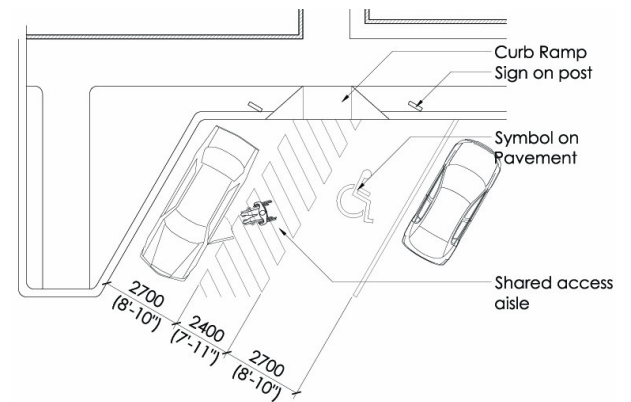

Figure 5.1.6(d)
Diagonal Designated Parking

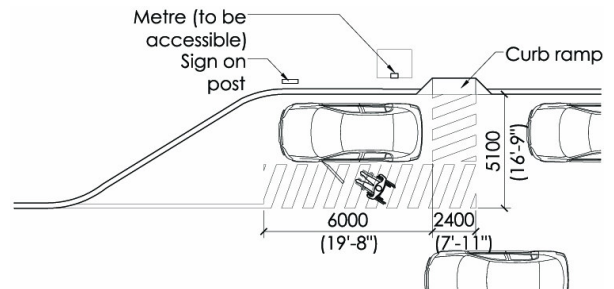

Figure 5.1.6(e)
Parallel Designated Parking



- b) Covered passenger pick-up/drop-off areas are recommended;
 - i) height clearance for car passenger zones is a minimum of 2750 mm (9 ft. 0 in.) but 3000 mm (10 ft. 0 in.) is recommended – **Figure 5.1.6(f)**.
 - ii) for special transit vehicles, such as DARTS buses, the headroom clearance is recommended to be 3650 mm (12 ft. 0 in.)
- c) Provide an access aisle – **Figure 5.1.6(g)** on the roadway that is
 - i) parallel and adjacent to the pedestrian walkway
 - ii) at least 2400 mm (7 ft. 10 in.) wide x 7300 mm (24 ft. 0 in.) long
 - iii) separated from the walkway by a curb containing a curb ramp that complies with section 5.1.5 Exterior Pedestrian routes.
- d) All designated passenger pick-up/drop-off areas should be marked with appropriate signage utilizing the “International Symbol of Accessibility”.

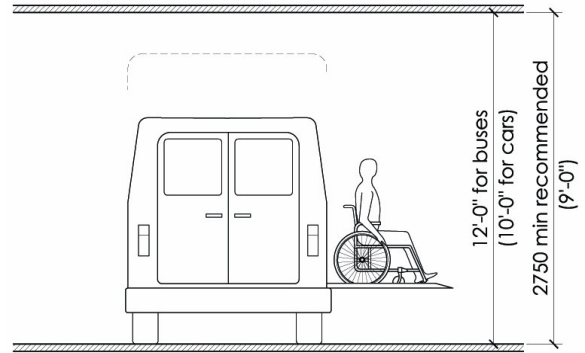

Figure 5.1.6(f)
Height Clearances at Pick-up/Drop-off Areas

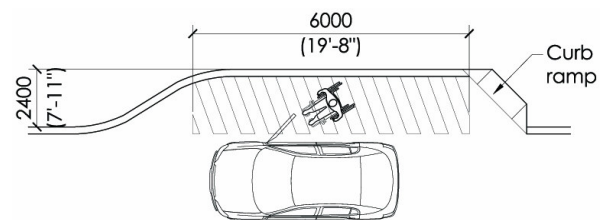

Figure 5.1.6(g)
Access aisle at passenger pick-up/drop-off

Related Sections:

- 5.1.4 Accessible Routes, Paths and Corridors
- 5.1.5 Exterior Pedestrian Routes
- 6.3 Materials and Finishes
- 6.4 Texture and Colour
- 6.5 Urban Braille
- 6.8 Detectable Warning Surfaces





Barriers and Obstacles

When crossing traffic at busy intersections, persons with varying physical limitations require different types of support in order to safely cross (e.g., audible signals, sufficient time, clear route, etc.).

Design Requirements

- 1) Signals at pedestrian crosswalks should be designed generally in accordance with requirements of the Highway Traffic Act and the Ontario Traffic Manual Book 12 - Traffic Signals - **Figure 5.1.7**. LED lights are preferred as they are brighter in daylight.
- 2) Both audible and flashing crossing signals should be provided as an aid to persons who have hearing or visual impairments.
- 3) Audible pedestrian signals should be loud enough to be heard clearly above the ambient noise (e.g., at least 15 decibels louder than ambient noise).
- 4) Two different audible pedestrian signals, identifying when it is safe to cross either direction, (as indicated by a separate tone) are required for persons with visual impairments.
- 5) Where the crossing distance is larger than usual, or the traffic flow determines it; a 3 stage crossing may be provided; whereby a safe area is provided (such as a traffic island) to traverse the distance in stages.
- 6) Tactile features should be provided as an aid to persons who have both hearing and vision limitations (e.g., a tactile or vibro-tactile feature on pushbuttons.).
- 7) In locations frequently used by seniors or persons with disabilities, crossing timing should be provided to permit pedestrians or persons in wheelchairs to cross safely.
- 8) Where pedestrian activated buttons are provided, they shall be clearly indicated.
- 9) Where possible, crosswalks and signals should be of a consistent design to promote familiarity of use.

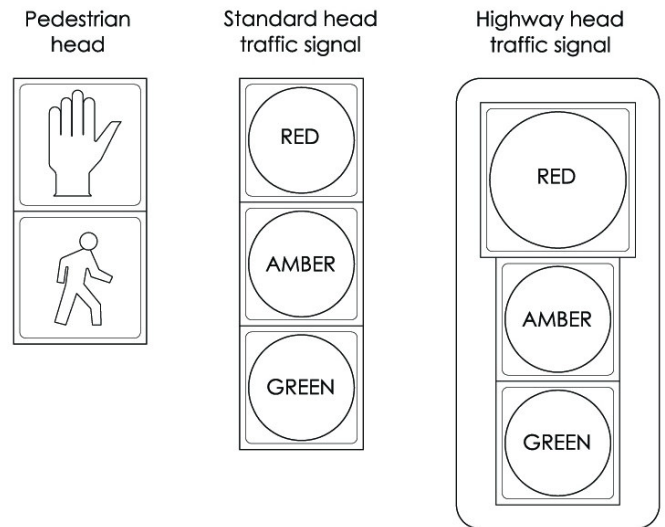

Figure 5.1.7
Traffic Symbols

Related Sections

5.1.5 Exterior Pedestrian Routes





Barriers and Obstacles

When designing entrances, consideration should be given to:

- the effects of weather and the speed at which a person with physical impairments can access the building;
- the conspicuousness of the entrance to assist someone with cognitive and or visual limitations; and
- the fact that these areas may serve many functions (e.g., waiting areas, etc.).

Design Requirements

1) Accessible Routes to Entrances

- a) Provide an accessible route from
 - i) the site boundary;
 - ii) accessible parking areas; and
 - iii) lay-bys and drop off zones to the main entrance and/or other accessible entrances.
- b) An accessible route to an entrance shall be 1525 mm (60 in.) minimum width (1675 mm (66 in.) width is preferred) constructed of a firm non-slip material.
- c) Accessible pedestrian routes to entrances should be designed so they do not cross into vehicular routes.

In situations where accessible pedestrian routes cross into vehicular routes - crossings with suitable curb ramps identified by bright yellow or white lines and/or distinct paving should be provided.
- d) On private property, provide rest areas every 30 meters, at least 1220 mm (48 in.) deep, located to one side of walkways. Where possible include space for a bench, and wheelchair, or scooter.
- e) If direct access is provided for pedestrians from an enclosed parking garage to the facility, at least one direct entrance from the parking garage to the facility must be accessible.
- f) If access is provided for pedestrians from a pedestrian tunnel or elevated walkway, one entrance to the facility from each tunnel or walkway must be accessible.



2) Canopies and Weather Protection

- a) Where possible, all main entrances and other accessible entrances should be protected by a suitable canopy or overhang.
- b) Where canopies project over passenger loading zones, provide sufficient headroom clearance (See section 5.1.6 *Vehicular Access*).
- c) Canopies of a distinctive size and contrasting colour may serve to help signify an entrance.

3) Entrance Design Considerations

- a) Accessible entrances provide direct access to persons using wheelchairs or scooters and are also frequently used as waiting areas for persons requiring assistance (e.g., waiting for a ride from special transit, taxis, family members, attendants or others) - **Figure 5.1.8(a)**.
- b) There should be enough waiting space inside the main accessible entrance, either in the vestibule or adjacent lobby, for at least two persons using wheelchairs. Such waiting areas should provide a clear view of the entrance and arrival area for taxis, buses and private vehicles.
- c) Accessible entrances should provide basic protection from the weather and include doors and vestibules that are useable autonomously by persons with varying disabilities.
- d) Where accessible entrances include security locks or other locking devices, a nearby call bell (or information telephone) should be available for persons requiring information or assistance.
- e) In public buildings, an accessible public telephone should be available near the accessible entrance to provide seniors and persons with varying disabilities with suitable telephone access (e.g., calling for a taxi or a ride).

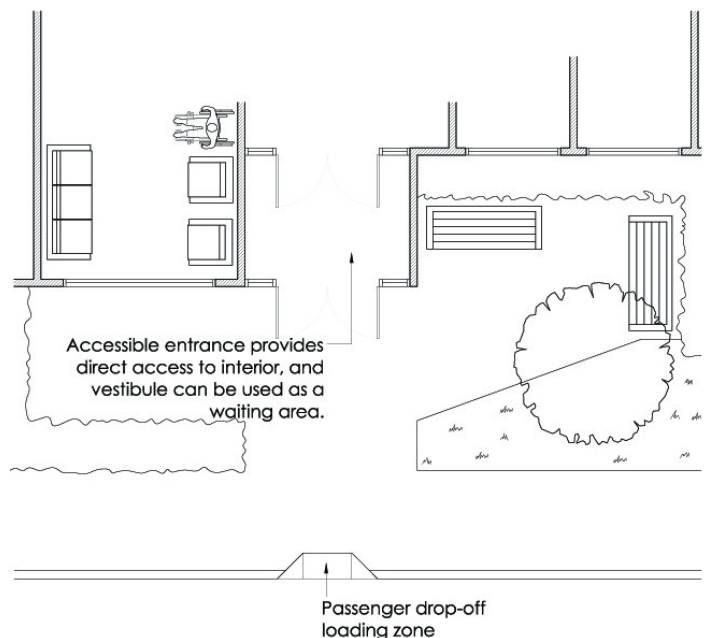

Figure 5.1.8(a)
Accessible Entrance



4) **Entrance Requirements**

- a) All entrances used by staff or the public shall be accessible and comply with this section.
 - i) In retrofit situations where it is deemed infeasible to make all staff and public entrances accessible, at least 50% of all staff and public entrances shall be accessible and comply with this section.
 - ii) In retrofit situations where it is deemed infeasible to make all public entrances accessible, the primary entrances used by staff and the public shall be accessible.
- b) An accessible public entrance must be provided to each tenancy in a facility.
- c) Public entrances that are secured shall be accessible, as required (e.g., police stations (See section 5.4.12 *Police Stations*) and municipal courts (See section 5.4.4 *Municipal Courts*)).
- d) If the only entrance to a facility or tenancy is a service entrance, that entrance shall be accessible.
- e) Entrances which are not accessible shall have directional signage complying with section 5.2.7 *Signage and Wayfinding* which indicates the nearest accessible entrance.
- f) Accessible entrances shall be identified with signage complying with applicable provisions of section 5.2.7 *Signage and Wayfinding*.

5) **Vestibules**

- a) See section 5.1.9 *Doors* for vestibules at accessible entrances.
- b) Interior vestibules to washrooms or other special areas should be fully accessible to persons using mobility aids.
- c) Vestibule depths should provide at least 1220 mm (48 in.) floor space, clear of door swings and/or other obstacles, for manoeuvring of mobility aids.
- d) Where interior doors swing towards a person using a wheelchair, at least 610 mm (24 in.) clear space should be available at the jamb, on the opening edge of the door, to allow persons using mobility aids easy access to the door (See section 5.1.9 *Doors*).



- e) Where doors swing away from a person using a mobility aid, at least 305 mm (12 in.) clear space should be available adjacent to the jamb on the opening edge of the door, for ease of use by persons using mobility aids.
- 6) **Waiting Areas**
 - a) For persons requiring information or services of assistance, waiting areas with loose furniture should be large enough to accommodate at least two persons using wheelchairs or scooters, in addition to other members of the public.
 - b) Waiting areas with fixed seating should include enough clear space for a minimum of two persons using wheelchairs or scooters.

Related Sections

- 5.1.1 Space and Reach Requirements
- 5.1.9 Doors
- 5.1.10 Gates, Turnstiles and Openings
- 5.4.1 Controls and Operating Mechanisms
- 6.2 Lighting
- 6.5 Urban Braille
- 6.6 Information Systems
- 6.7 Signage and Wayfinding
- 6.9 Windows, Glazed Screens and Sidelights



Barriers and Obstacles

Doors are an integral part of our buildings and facilities, and as such, much consideration should be given to their function for universal access: sufficient width, level floor transitions, direction of door swings, hardware, material and colours.

Design Requirements

- 1) Doors shall comply with this section where:
 - a) they are an element of an accessible route or an accessible entrance.
 - b) They are required under section 5.4.2 *Emergency Exits, Fire Evacuation and Areas of Rescue Assistance*.
- 2) **Opening Widths:** the clear opening width of doorways shall be at least 950 mm (37-1/2 in.).
 - a) Swinging doors; when measured between the face of the door or the panic hardware and the face of the stop, with the door open 90° - **Figures 5.1.9(a), (b) and (c)**.
 - b) Sliding doors; when measured between the edge of the open door and the doorframe - **Figure 5.1.9(d)**.
 - c) Retrofit situations: Door openings may be reduced to 810 mm (32 in.), where it is deemed infeasible to provide the above clearance.

Exception: Doors not requiring full user passage i.e. shallow closets may be reduced to 510 mm (20 in.).

- 3) **Manoeuvring areas** at doorways:
 - a) Doorways shall have
 - i) a level manoeuvring area on the push and pull sides of a door.
 - ii) A clear floor area beside the latch edge (extending the full height of the door) complying with **table 5.1.9** - **Figures 5.1.9(e), (f), (g) and (h)**.
 - iii) The width of the clear floor area required in **Table 5.1.9** is measured from the inside of the doorframe.
 - b) Where a door leads to a ramp landing, an additional area may be required.
- 4) **Multiple leaf doorways:**
 - a) If doorways have more than one independently operated leaf, at least one active leaf shall
 - i) Comply with sections 5.1.9.2 *Opening Widths* and 5.1.9.3 *Manoeuvring Areas*; and

Context	Floor space required		
	Depth	Width	Space beside latch
Side-hinged door - Front approach (Figure 4.1.6.4)			
Pull side	1525 (60 in.)	1600 (63 in.) (*1525 (60 in.))	600 (24 in.)
Push side	1370 (54 in.)	1250 (49-1/4 in.) (*1220 (48 in.))	300 (12 in.)
Side-hinged door - Latch-side approach (Figure 4.1.6.3)			
Pull side	1370 (54 in.) (*1220 (48 in.))	1600 (63 in.) (*1525 (60 in.))	600 (24 in.)
Push side	1370 (54 in.) (*1060 (42 in.))	1525 (60 in.)	600 (24 in.)
Side-hinged door - Hinge-side approach (Figure 4.1.6.2)			
Pull side	1930 (76 in.) (*1525 (60 in.))	1930 (76 in.) (*1525 (60 in.))	600 (24 in.)
Push side	1370 (54 in.) (*1060 (42 in.))	1830 (72 in.)	450 (18 in.)
Sliding door (Figure 4.1.6.5)			
Front approach	1370 (54 in.)	1060 (42 in.) (*920 (36 in.))	50 (2 in.)
Side approach	1370 (54 in.) (*1060 (42 in.))	1550 (61 in.) (*1370 (54 in.))	540 (21-1/2 in.)

In retrofit situations where it is technically infeasible to provide to provide the required clearances at doors, the clearances may be reduced as shown by the *.

Table 5.1.9
Space at Doors

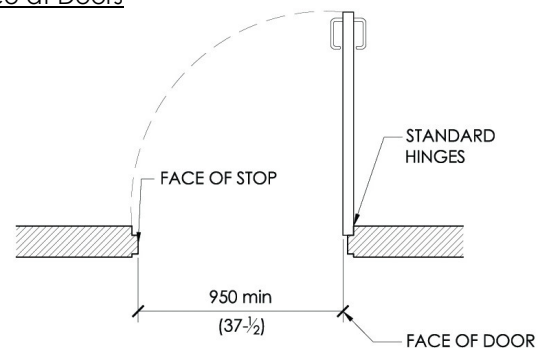

Figure 5.1.9(a)
Minimum Clear Width at Doors

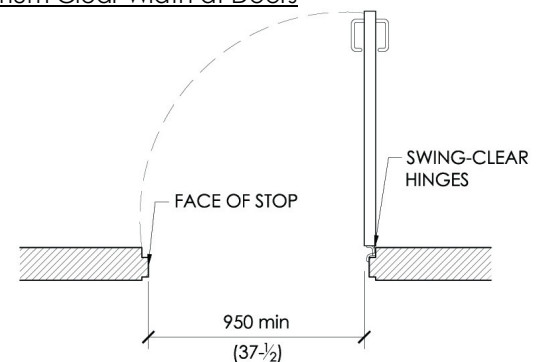

Figure 5.1.9(b)
Minimum Clear Width at Doors



- ii) where only one door is accessible in a bank of doors, be identified by the International Symbol of Access.
- b) Double doors; avoid the use of a centre post.
- c) It is preferable if all doors are accessible.
- 5) **Revolving Doors:** Where revolving doors are used, an adjacent door shall be provided that complies with section 5.1.9 Doors.
- 6) **Two doors in series:** The distance between two swinging doors in series shall be at least 1370 mm (54 in.) plus the width of any doors swinging into the space - **Figures 5.1.9(i) and 5.1.9(j)**.
- 7) **Thresholds:**
 - a) Thresholds shall:
 - i) be not more than 13 mm (1/2 in.) high, except as permitted by b)
 - ii) at exterior sliding doors, be not more than 19 mm (3/4 in.) high, and
 - iii) wherever over 6 mm high, be bevelled at a slope not steeper than a ratio of 1:2 (50%).
 - b) Level thresholds are preferred.
- 8) **Operating Devices:**
 - a) Operating devices such as handles, pulls, latches or locks shall:
 - i) comply with section 5.4.1 Controls and Operating Mechanisms.
 - ii) be mounted 800 mm (31-1/2 in.) to 1200 mm (47-1/4 in.) from the floor
 - iii) on a sliding door, be exposed and usable from both sides.
 - b) Provide:
 - ii) lever handles on doors with latches - **Figure 5.1.9(i)**.
 - iii) 'U' shaped door levers (reduces the risk of clothes catching or injury from the exposed lever end) - **Figure 5.1.9(i)**.
 - iv) panic hardware that does not interfere with passage through a doorway.
 - v) kick plates at least 250 mm (10 in.) high on the push side of doors in high traffic areas.
- 9) **Door Closers:**
The sweep period of door closers shall be adjusted so that the door will take 3 seconds or move from an open position of 90° to a semi-closed position of approximately 12°.

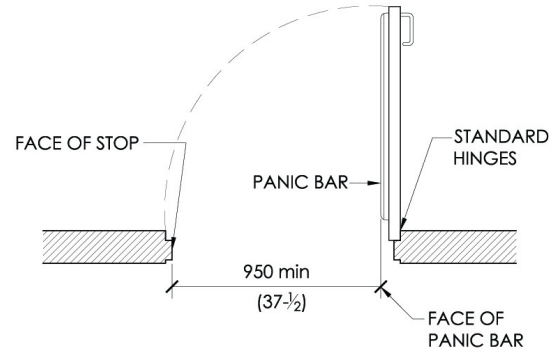

Table 5.1.9(c)
Minimum Clear Width at Doors

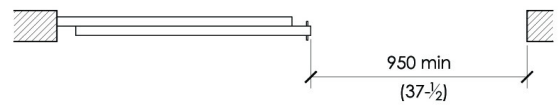

Figure 5.1.9(d)
Minimum Clear Width at Doors

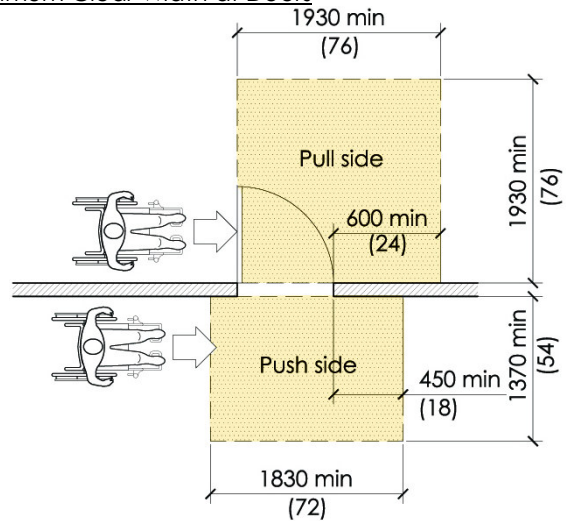

Figure 5.1.9(e)
Hinge Side Approach at Hinged Doors



- 10) **Door-Opening force:** The maximum force for pushing or pulling a door shall be:
- 38N for exterior swinging doors;
 - 22N for interior swinging doors; and
 - 22N for sliding or folding doors.
- 11) **Power assisted doors**
- General
 - Power assisted swinging doors shall:
 - take 3 seconds or more to move from a closed position to a fully open position;
 - remain fully open for a minimum of 5 seconds, the length of time is affected by the distance between the manual power assist control and the door);
 - require a force of not more than 66N to stop door movement; and
 - where they open in a route of travel, have cane detectable guard rails or other barriers at right angles to the wall containing the door - **Figure 5.1.9(h)**, and should have minimum clearance of 305 mm (12 in.) from the door.
 - Power assisted glass sliding doors are preferred for the following reasons:
 - Manual activation is not required;
 - Do not require guard rails for door-swing protection;
 - Maintains the flow of traffic; and
 - Automatic sliding doors are available that meet the requirements for an exit as defined by the Ontario Building Code.
 - At least one power-operated door should be provided at the main entrances to buildings.
 - Power-operated doors should be considered for high traffic areas e.g. individual and public washrooms.

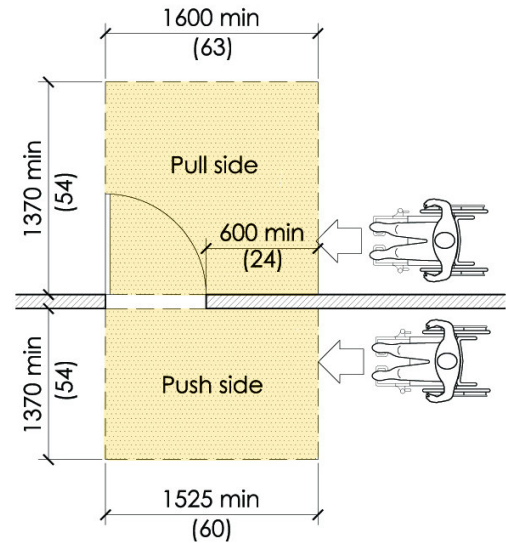

Figure 5.1.9(f)
Latch Side Approach at Hinged Doors

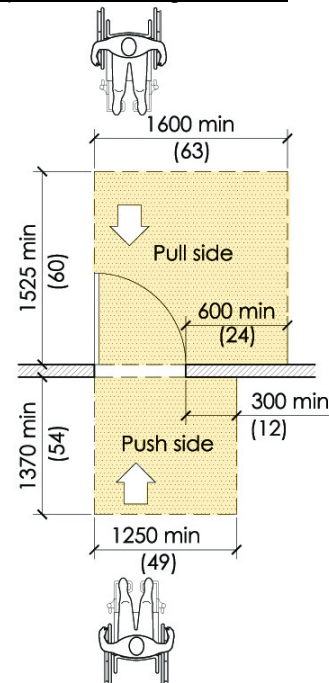

Figure 5.1.9(g)
Front Approach at Hinged Doors



b) Location of controls

For doors that are not automatically activated, controls to open power-assisted doors shall:

- i) be located along the route of travel be clearly visible before reaching the door;
- ii) have a clear floor area of 750 mm x 1200 mm (29-1/2 in. x 47-1/4 in.) in front of them;
- iii) be clear of the door swing or any other fixture; and
- iv) be located at a height of 800 mm to 1200 mm (31-1/2 in. to 47-1/4 in.) from the floor.

c) Controls

The controls for power assisted doors shall consist of activation pads that:

- i) comply with section 5.4.1 *Controls and Operating Mechanisms*;
- ii) have dimensions of at least 25 mm x 75 mm (1 in. x 3 in.). 100 mm (4 in.) diameter buttons are preferred;
- iii) are operable by touching any part of surface with a fist or an arm;
- iv) are marked with the International Symbol of Access; and
- v) where pressure-sensitive mats, overhead beams or proximity scanners are used to detect traffic, the layout of mat, beam or scanner coverage shall ensure that wheelchair users are detected.

12) **Transparent Glazing**

- a) Where transparent glazing is incorporated in a door see section 5.2.9 *Windows, Glazed screens and Sidelights*.
- b) Doors made entirely of transparent glazing shall have a bright colour contrasting horizontal strip and a vertical strip to indicate the leading edge (See section 5.2.9 *Windows, Glazed Screens and Sidelights*).
- c) Where a transparent door occurs in a system or series of transparent units, it is recommended that the entrance be clearly identified, so that a person with limited vision can recognize the operable unit (i.e. the door).

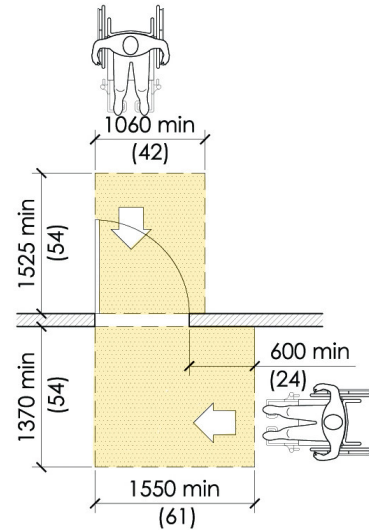

Figure 5.1.9(h)
Front and Side Approach at Sliding Doors

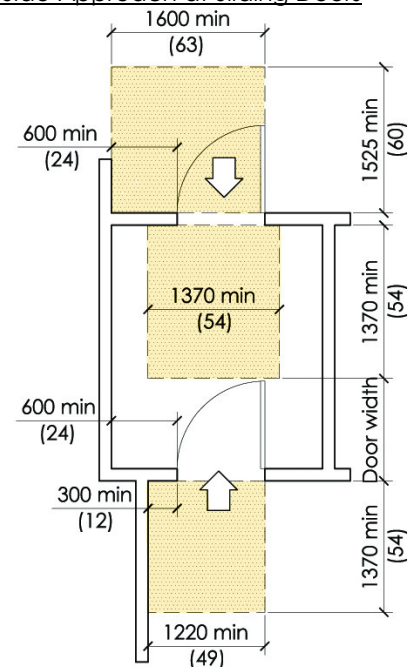

Figure 5.1.9(i)
Manoeuvring Space at Doors in Series



13) **Colour Contrasting**

- a) Doors shall incorporate pronounced colour contrast or visible feature to differentiate them from the surrounding environment.
- b) Door handles and other operating mechanisms shall incorporate pronounced colour contrast to differentiate them from the door itself.

14) **Mats and Mat Sinkages**

- a) Permanent mats and metal gratings at entrances and in vestibules shall be sunk level with the floor, so as not to create a tripping hazard.
- b) Occasional mats (e.g., runners used in inclement weather) should be level with the floor surface and/or have a gently bevelled edge, so as not to create a tripping hazard.
- c) Runners used to define a preferred route (e.g., to information desks) should lead directly to the desired objective with no obstacles encroaching into the required route.
- d) Runners should be continuous where possible and colour/tone differentiated from the floor.

Related Sections

- 5.1.1 Space and Reach Requirements
- 5.1.3 Protruding Objects
- 5.1.4 Accessible Routes, Paths and Corridors
- 5.1.8 Entrances
- 5.2.1 Toilet and Bathing Facilities
- 5.4.2 Emergency Exits, Fire Evacuation and Areas of Rescue Assistance
- 6.9 Windows, Glazed Screens and Sidelights

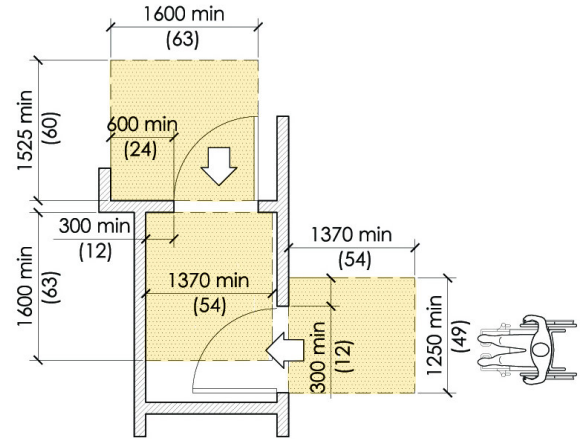

Figure 5.1.9(j)
Manoeuvring Space at Doors in Series

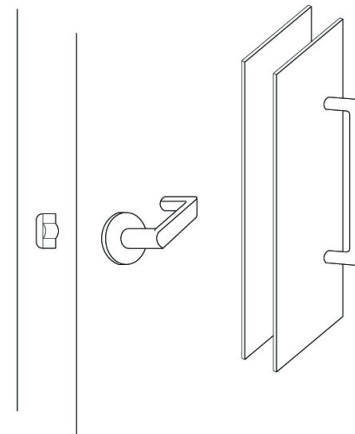

Figure 5.1.9(k)
Examples of Accessible Hardware

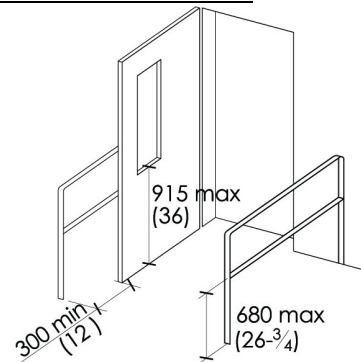

Figure 5.1.9(m)
Detectable Safety Guards





Barriers and Obstacles

The single-bar gates designed to be at a convenient waist height for ambulatory persons are at neck and face height for children and persons in wheelchairs.

Revolving turnstiles are a physical impossibility for a person in a wheelchair to negotiate. They are also difficult for persons using canes or crutches, or persons with poor balance. An adjacent opening of an appropriate width is essential for wheelchair access, as well as access for those using other mobility devices, strollers, walkers or delivery carts.

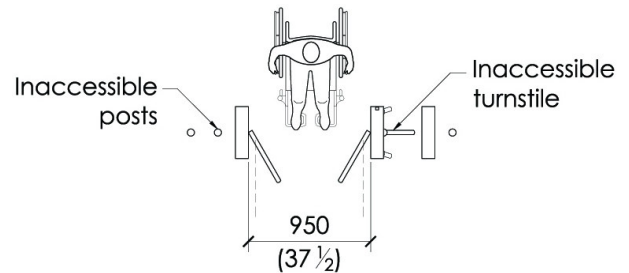

Figure 5.1.10
Access at Turnstile

Design Requirements

- 1) Gates, turnstiles and openings shall comply with the following:
 - a) Where gates or openings are provided through fences or screens to public use areas beyond, such openings shall be accessible.
 - i) A minimum of a 950 mm (37-1/2 in.) wide opening, to permit free passage of a person in a wheelchair should be provided - **Figure 5.1.10**.
 - ii) Hardware should be suitable for autonomous use, and any closing device should not be spring-loaded.
 - b) Where turnstiles or other ticketing control devices that are not wheelchair accessible are utilised, then a gate or opening which is accessible shall also be provided in the same location.
 - c) Turnstiles shall incorporate a pronounced colour contrast, to differentiate them from the surrounding environment.
 - d) Where gates are incorporated into a chain-link fencing system, the poles at either side of the gate shall incorporate a pronounced colour contrast from the fence and the surrounding environment.

Related Sections

- 5.1.1 Space and Reach Requirements
- 5.1.9 Doors
- 5.4.1 Controls and Operating Mechanisms
- 6.6 Information Systems
- 6.7 Signage and Wayfinding
- 6.9 Windows, Glazed Screens and Sidelights



Barriers and Obstacles

To people with mobility limitations, many public interior circulation paths are too narrow to accommodate various mobility aids.

For people with visual limitations, unexpected level changes are hazardous.

Seniors and people with limited strength endurance may be challenged by long paths of travel without handrail support or resting places.

Provisions for the following have been considered:

- Aisles and Passages
- Corridors and Hallways
- Safe Holding Areas

Design Requirements

1) Aisles and Passages

- In high-use public areas, aisles and passageways shall be a minimum of 1830 mm (72 in.) wide to allow two persons using wheelchairs or scooters to pass each other easily. A 1370 mm (54 in.) minimum width shall be provided to allow one person using a wheelchair and one ambulatory person to pass - **Figure 5.1.11(a)**.
- In low-use areas and offices etc., clear aisle space and passageways between walls, glazed screens, furniture and/or other major obstacles shall be 1060 mm (41-3/4 in.) minimum to accommodate users of mobility aids.
- Where aisles that are 1060 mm (41-3/4 in.) wide are extensive in length or terminate in a dead end, a turning space of 1600 mm x 1600 mm (63 in. x 63 in.) minimum at 30 m (98 ft. 6 in.) intervals shall be provided.

2) Corridors and Hallways

- High-use accessible public corridors and paths of travel shall be a minimum of 1830 mm (72 in.) in width, with turning spaces of a minimum 1600 mm (63 in.) in diameter every 30 m (98 ft. 6 in.).
- Corridors in all institutional facilities such as hospitals, nursing homes and homes for seniors, shall comply with Ministry of Health guidelines.
- Corridors serving residential suites shall be a minimum width of 1060 mm (41-3/4 in.) with turning locations not greater than 30 m (98 ft. 6 in.) apart and at ends of corridors.

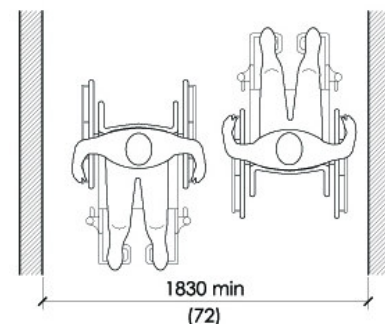
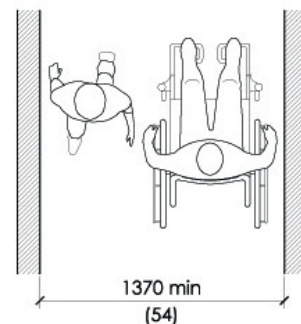
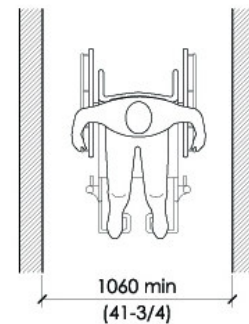

Figure 5.1.11(a)
Access Widths (from Low-use to High-use Corridors)



- d) Hallways within accessible residential or overnight suites, as well as aisles in public areas and workspaces etc., shall be a minimum of 1065 mm (42 in.) wide.
- e) Additional space shall be available where persons using mobility aids must manoeuvre around obstacles in corridors or hallways.
- f) Interior open stairs shall have a detectable guard underneath - **Figure 5.1.11(b)**.
- g) Wherever extended length corridors are provided, consideration should be given to the inclusion of a suitable and colour contrasted handrail, on at least one side of the corridor, as an aid to seniors and persons with limited mobility.
- h) In extended length corridors of 40 m (131 ft. 3 in.) or more, consideration should be given to the provision of a bench or other seating, located at intermediate points along the corridor for seniors and others with limited mobility.

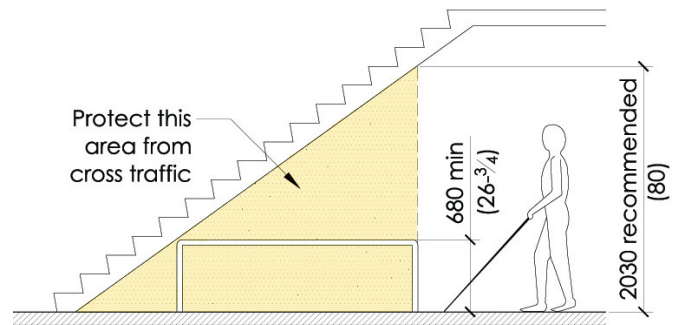

Figure 5.1.11(b)
Interior Open Stairs Protected Area

3) Safe Holding Areas

Where a safe holding area is included as part of the emergency plan for persons with disabilities, such holding areas should:

- a) accommodate a number of persons using various mobility aids (e.g., wheelchairs or scooters);
- b) be located in logical locations on each floor, above or below grade, that are easy to identify by persons who have visual impairments and accessible to wheelchair and scooter users; and
- c) have separate emergency lighting and ventilation systems and a two-way voice communication system linked to the fire control centre.

Related Sections

- 5.1.3 Protruding Objects
- 5.1.4 Accessible Routes, Paths and Corridors
- 5.1.8 Entrances
- 5.1.9 Doors
- 5.1.12 Ramps
- 5.1.13 Stairs
- 5.1.15 Escalators
- 5.1.16 Elevators
- 5.1.17 Platform Lifts
- 5.4.2 Emergency Exits, Fire Evacuation and Areas of Rescue Assistance



Barriers and Obstacles

Gentle slopes (ramps) can serve as a great tool to universal design whereby almost all persons are able to use them (some people with limited ankle movement may prefer stairs).

In many scenarios ramps are either added as an afterthought or retrofitted, into existing spaces, the end result can be cumbersome. They can be difficult to negotiate and consume a large amount of space. A steeply inclined ramp is too difficult to push up when using a wheelchair and may cause it to tip backward. It is also dangerous to descend, requiring an individual to slow their speed. However, where a change in level already exists or cannot be avoided, a properly designed ramp can provide access for those using mobility devices, pushing strollers or moving objects on a trolley.

Design Requirements

- 1) Any part of an accessible route with a slope steeper than 1:25 shall be considered a ramp and shall comply with this section.
- 2) Accessible ramps shall be on an accessible route complying with section 5.1.4 *Accessible Routes, Paths and Corridors*.
- 3) The running slope shall have a maximum slope of 1:20 and the maximum horizontal length between landings shall not exceed 9 m (29 ft. 6 in.) - **Figures 5.1.12(a), 5.1.12 (b), and 5.1.12 (c)**.
- 4) In retrofit situations where it is deemed infeasible to provide a ramp with a running slope between 1:20 and 1:24.9, a running slope not steeper than 1:12 may be used, and the maximum horizontal length between landings shall not exceed 9 m (29 ft. 6 in.).
- 5) The maximum cross slope of ramp surfaces shall be 1:50.
- 6) The minimum width of a ramp between handrails shall be 950 mm (37-1/2 in.).
- 7) Ramps shall have level landings at the top and bottom of each run and also where the ramp changes direction.
- 8) Wherever possible provide clues for the visually impaired, such as:
 - a) a coloured or textured clue at top and bottom of ramp.
 - b) a coloured or textured clue in handrails at top and bottom of ramp
 - c) a coloured or textured field on the surface of the ramp to differentiate from a level surface.

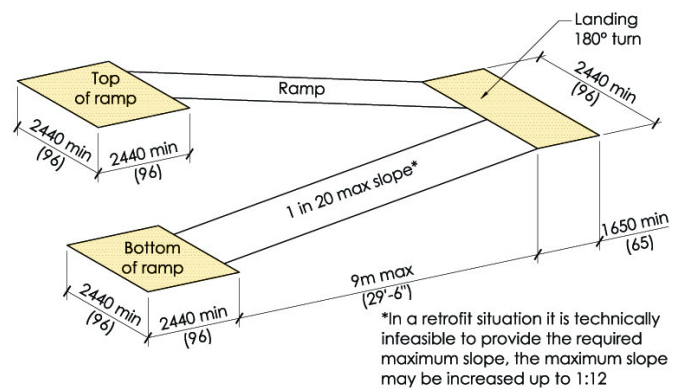

Figure 5.1.12(a)
Minimum Ramp Landing Dimensions

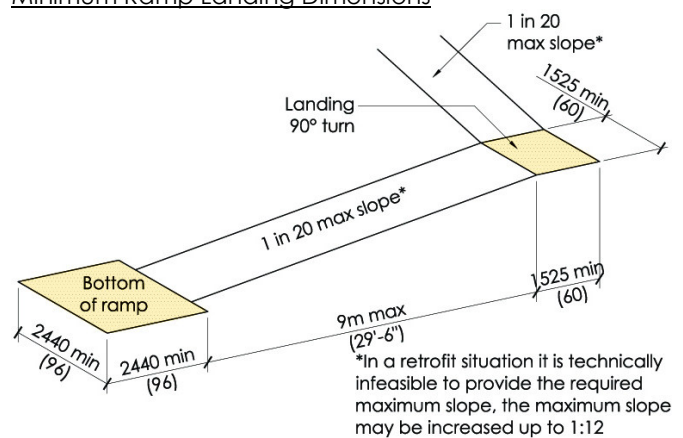

Figure 5.1.12(b)
Minimum Ramp Landing Dimensions

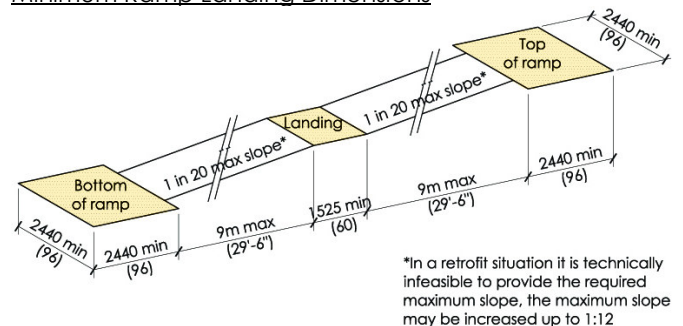

Figure 5.1.12(c)
Minimum Ramp Landing Dimensions



- 9) Landings shall:
 - a) be at least as wide as the widest ramp run leading to it;
 - b) have a minimum size not less than 2440 mm x 2440 mm (8 ft. x 8 ft.) if located at the top or bottom of a ramp or if served by a doorway - **Figures 5.1.12(a), 5.1.12(b)** and **5.1.12(c)**;
 - c) in a retrofit situation where creating a suitably sized landing is deemed infeasible, the required landing size may be reduced to 1525 mm x 1525 mm (60 in. x 60 in.);
 - d) where an intermediate landing at the switchback of a U-shaped ramp - **Figure 5.1.12(a)** - have a length not less than 1650 mm (65 in.) and a width not less than 2440 mm (96 in.);
 - e) in a retrofit situation where creating a suitably sized landing is deemed infeasible, the required landing length may be reduced to 1525 mm (60 in.). The width may be reduced to 2120 mm (83-1/2 in.);
 - f) where an intermediate landing at the corner of an L-shaped ramp - **Figure 5.1.12(b)** - have a length and width not less than 1525 mm (60 in.);
 - g) where an intermediate landing at a straight ramp - **Figure 5.1.12(c)** -, have a length not less than 1525 mm (60 in.); and
 - h) where it meets a slope change, have a 50 mm ± 10 mm (2 in. ± 1/2 in.) wide colour-contrasted strip equal to the width of the ramp.
- 10) Ramp and landing surfaces shall be slip-resistant.
- 11) Outdoor ramps and their approaches shall be designed so that water will not accumulate on walking surfaces.
- 12) Ramps and landings not at grade shall have a wall or guard on both sides.
- 13) Where a guard is provided, it shall:
 - a) be not less than 1070 mm (42 in.) measured vertically to the top of the guard from the ramp surface;



- b) be designed so that no member, attachment or opening between 140 mm and 915 mm (5-1/2 in. and 36 in.) above the ramp surface being protected by the guard will facilitate climbing - **Figure 5.1.12(d)**; and
 - c) be provided with:
 - i) a curb at least 50 mm (2 in.) high on any side of the ramp where no solid enclosure or solid guard is provided - **Figure 5.1.12(d)**; and
 - ii) railings or other barriers that extend to within 50 mm (2 in.) of the finished ramp, or have a curb not less than 50 mm (2 in.) high - **Figure 5.1.12(d)**.
- 14) A ramp run with a rise greater than 150 mm (6 in.) shall have handrails which:
- a) are on both sides;
 - b) comply with section 5.1.14 Handrails;
 - c) are continuous on the inside of switchback (U-shaped) or dogleg (L-shaped) ramps;
 - d) when not continuous, extend horizontally at least 305 mm (12 in.) beyond the top and bottom of the ramp and return to the wall, floor, or post - **Figure 5.1.12(e)**;
 - e) measure between 865 mm and 915 mm (34 in. and 36 in.) from the ramp surface to the top of the handrail; and
 - f) have a distance between handrails of 950 mm to 1000 mm (37-1/2 in. to 39-1/2 in.).

Exception: Where a ramp serves as an aisle way for fixed seating, the requirements for ramp handrails do not apply.

- 15) As many people find using steps easier and safer than using a ramp, both stairs and a ramp should be provided in any one location.

Related Sections

- 5.1.1 Space and Reach Requirements
- 5.1.2 Ground and Floor Surfaces
- 5.1.9 Doors
- 5.1.14 Handrails
- 6.1 Glare and Light Sources
- 6.2 Lighting
- 6.3 Materials and Finishes
- 6.4 Texture and Colour
- 6.7 Signage and Wayfinding
- 6.8 Detectable Warning Surfaces

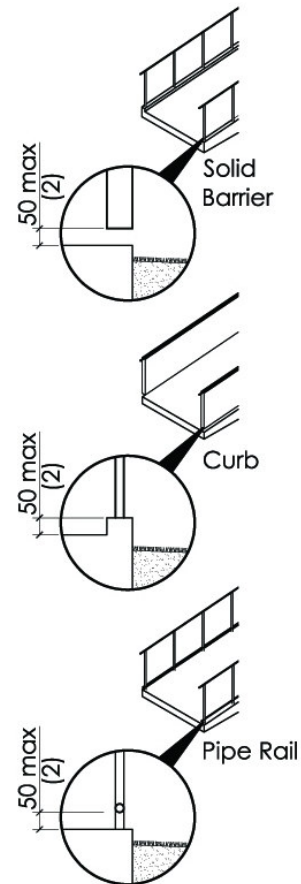

5.1.12(d)
Edge Protection at Ramps

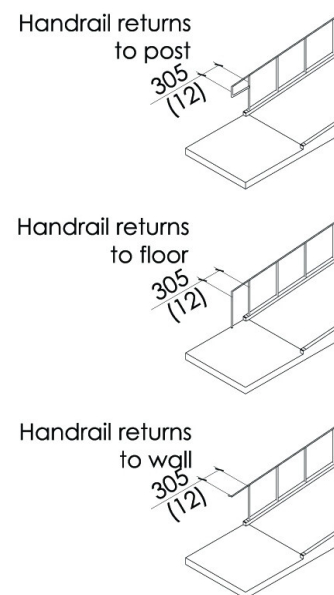

Figure 5.1.12.e
Edge Protection at Ramps





Barriers and Obstacles

Stairs that are comfortable for an adult may be challenging for children, seniors or persons of short stature. Poorly designed nosing can present tripping hazards, particularly to persons with prosthetic devices or those using canes. A person with a visual impairment may be unaware of them or, once negotiating them may have difficulty assessing the rise and run.

Design Requirements

- 1) New interior and exterior stairs shall comply with this section.
- 2) A flight of stairs shall:
 - a) have uniform riser heights and tread depths;
 - b) have risers not more than 200 mm (8 in.) and not less than 125 mm (5 in.) high; run not less than 230 mm (9 in.) and not more than 355 mm (14 in.) deep, measured from riser to riser - **Figure 5.1.13(b)**;
 - c) where interior, have no less than 3 risers;
 - d) have no open risers;
 - e) be illuminated to at least 100 lux (9.2 ft. – candles); and
 - f) have no strongly patterned covering on risers and treads that would obscure the definition of the tread edges.
- 3) Nosings shall:
 - a) project not more than 25 mm (1 in.);
 - b) have no abrupt undersides;
 - c) have a curved or bevelled leading edge of the tread between 8 mm and 13 mm (1/3 in. and 1/2 in.);
 - d) where projecting, be sloped to the riser at an angle not less than 60 degrees to the horizontal - **Figure 5.1.13(b)**;
 - e) be slip-resistant; and
 - f) have the horizontal and vertical surface of the stair nosing in colour contrast with the remainder of the riser and tread that:
 - i) is 50 mm ± 10 mm (2 in. ± 1/2 in.) wide;
 - ii) extends the full width of the tread; and
 - iii) is slip resistant.
- 4) Stairs shall incorporate detectable warning surfaces that comply with section 6.8 *Detectable Warning Surfaces*.

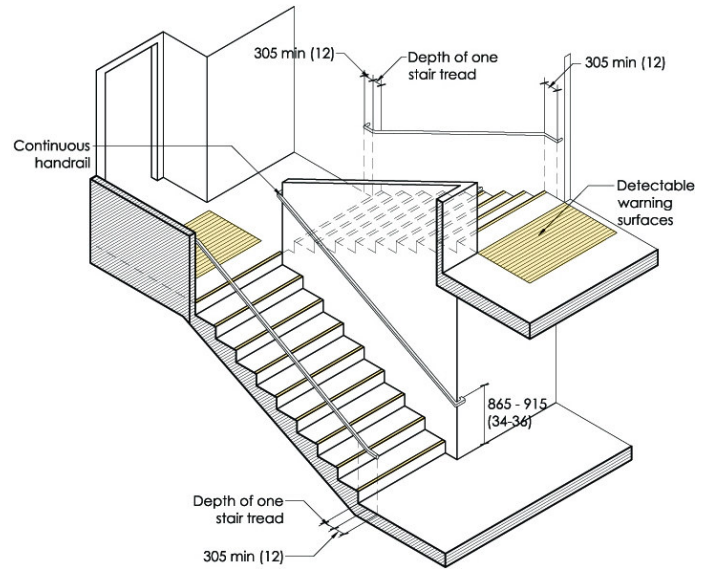

Figure 5.1.13(a)
Stair Design Criteria

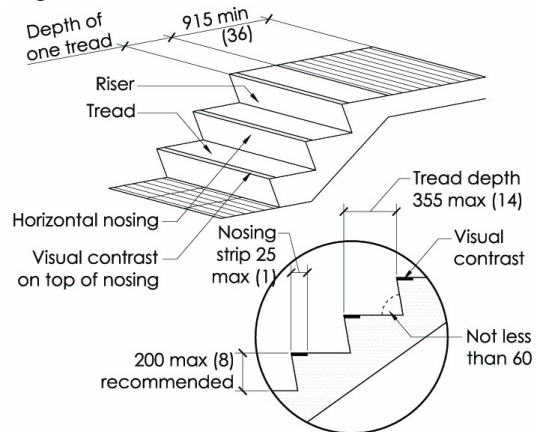

Figure 5.1.13(b)
Stair Details



- 5) Handrails for stairs shall:
- a) comply with section 5.1.14 *Handrails*;
 - b) be installed on both sides;
 - c) be of uniform height, ranging between 865 mm and 915 mm (34 in. and 36 in.) from the stair nosing - **Figure 5.1.13(a)**;
 - d) have a continuous inside handrail on U-shaped or L-shaped stairs; where not continuous;
 - e) extend horizontally at the top and bottom of the stairs not less than 305 mm (12 in.), at a height ranging between 865 mm and 915 mm (34 in. and 36 in.) - **Figure 5.1.13(a)**; and
 - f) return to the wall or post in a manner that will not create a hazard or obstruct pedestrian travel.

Related Sections

- 5.1.1 Space and Reach Requirements
- 5.1.2 Ground and Floor Surfaces
- 5.1.5 Exterior Pedestrian Routes
- 5.1.9 Doors
- 5.1.14 Handrails
- 6.1 Glare and Light Sources
- 6.2 Lighting
- 6.3 Materials and Finishes
- 6.4 Texture and Colour
- 6.7 Signage and Wayfinding
- 6.8 Detectable Warning Surfaces



Barriers and Obstacles

Many handrails do not address the wide variety of users who would benefit from their safety aspect. A handrail suited to an adult's hand may be too high for a child, and too wide for a person with arthritis to use. They are often interrupted by newel posts or other construction elements that interrupt a handhold. For persons with visual impairments, they are difficult to see if similar in colour to the wall. Additionally, handrails that are not extended past the top and bottom risers of stairs do not provide adequate support for preparation to ascend or descend stairs.

Design Requirements

- 1) Handrails shall:
 - a) have a circular section 30 mm to 40 mm (1-1/4 in. to 1-1/2 in.) in diameter or any non-circular shape, with a graspable portion that has a perimeter not less than 100 mm (4 in.) and not more than 155 mm (6 in.) whose largest cross-sectional dimension is not more than 57 mm (2-1/4 in.) - **Figures 5.1.14(a), 5.1.14(b) and 5.1.14(c)**;
 - b) be free of any sharp or abrasive elements;
 - c) have continuous gripping surfaces, without interruption by newel posts, other construction elements, or obstruction that can break a handhold; and
 - d) have a clear space between the handrail and the wall of:
 - i) 40 mm to 45 mm (1-1/2 in. to 1-3/4 in.) - **Figure 5.1.14(a)**;
 - ii) at least 60 mm (2-1/2 in.) where the wall has a rough surface - **Figure 5.1.14(d)**; and
 - iii) 40 mm to 45 mm (1-1/2 in. to 1-3/4 in.) underneath the handrail; and
 - e) be terminated in a manner that will not obstruct pedestrian travel or create a hazard.
 - f) be of uniform height from the finished floor, ranging between 865 mm and 915 mm (34 in. and 36 in.) from the stair nosing.

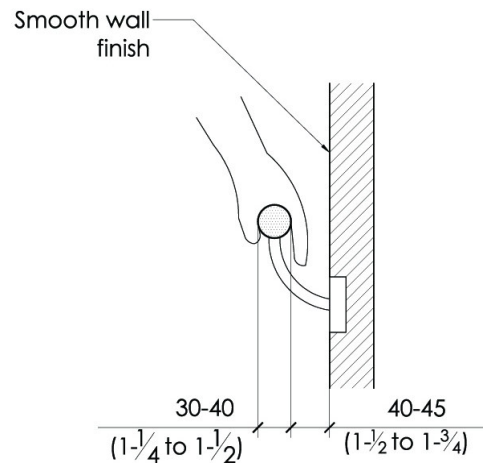

Figure 5.1.14(a)
Handrail

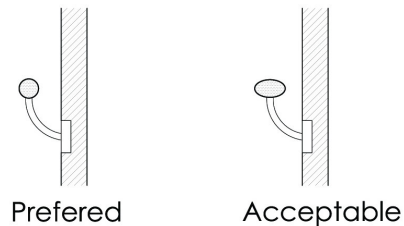

Figure 5.1.14(b)
Preferred and Acceptable Handrail Shape

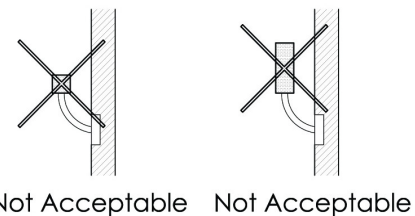

Figure 5.1.14(c)
Un acceptable Handrail Shape

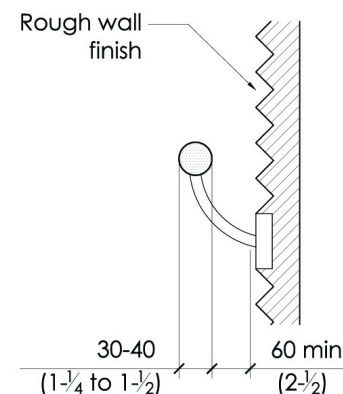

Figure 5.1.14(d)
Handrail at Rough Wall



- 2) A recess containing a handrail shall extend at least 450 mm (17-3/4 in.) above the top of the rail - **Figure 5.1.14(e)**.
- 3) Handrails and their supports shall be designed and constructed to withstand the loading values obtained from the nonconcurrent application of:
 - a) a concentrated load of not less than 0.9 kN (200 lbs.) applied at any point and in any direction; and
 - b) a uniform load of not less than 0.7 kN/m (47 lbs./ft.) applied in any direction to the handrail.
- 4) Handrails shall incorporate a pronounced colour contrast, to differentiate them from the surrounding environment.

Related Sections

- 5.1.1 Space and Reach Requirements
- 5.1.12 Ramps
- 5.1.13 Stairs
- 6.4 Texture and Colour

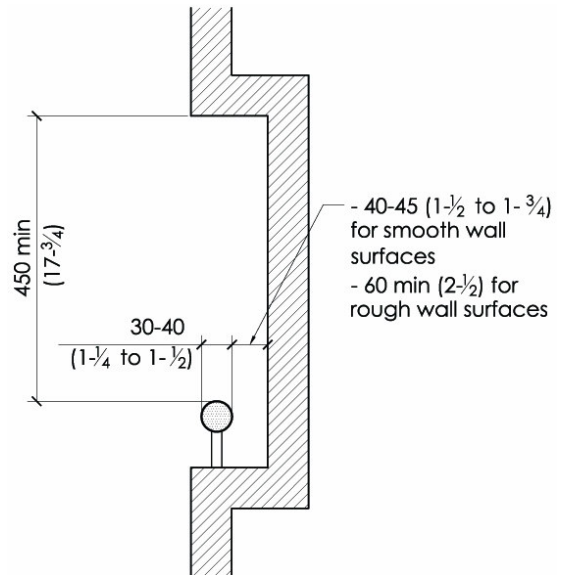

Figure 5.1.14(e)
Handrail in Recess



Barriers and Obstacles

Entering and exiting an escalator can be challenging for many persons. This is largely due to the speed of the escalator operation. In addition, the lack of contrast on the edges of steps makes it difficult for many to determine the position of the steps or judge their speed.

Design Requirements

- 1) Escalators shall:
 - a) include high definition (colour contrast) of tread edges and nosing;
 - b) have detectable warning surfaces at the head and foot of the escalator that comply with 6.8 *Detectable Warning Surfaces*;
 - c) have a matte finish on the surface of the tread, to minimise reflected glare; and
 - d) be illuminated by a minimum of 200 lux (18.4 ft-candles), evenly distributed, from a low-glare light source.

Related Sections

- 5.1.1 Space and Reach Requirements
- 5.1.2 Ground and Floor Surfaces
- 6.1 Glare and Light Sources
- 6.2 Lighting
- 6.3 Materials and Finishes
- 6.4 Texture and Colour
- 6.8 Detectable Warning Surfaces





Barriers and Obstacles

Elevators, if improperly designed, can be difficult to use by persons with disabilities and seniors. Buttons can be hard to read, reach and push. Without audible signals they can be disorienting. For those whose mobility is impaired the doors can close too quickly.

Design Requirements

- 1) Where required:
 - a) one passenger elevator complying with this section shall serve each level, including mezzanines, in all multi-storey facilities, unless exempted below. If more than one elevator is provided, each passenger elevator shall comply with this section.
 - b) freight elevators need not meet the requirements of this section, unless the only elevators provided are used as combination passenger and freight elevators for use by the public and employees.
- 2) Elevators are not required:
 - a) in facilities that are less than three storeys and not open to the general public;
 - b) to provide access to elevator pits, elevator penthouses, mechanical rooms, piping or equipment catwalks;
 - c) when accessible ramps complying with section 5.1.12 Ramps are used in lieu of an elevator;
 - d) when platform lifts complying with 5.1.17 Platform Lifts and applicable Provincial Codes are used under the following conditions:
 - i) to provide an accessible route to a performing occupancy;
 - ii) to provide access to incidental occupied spaces and rooms that are not open to the general public and which house no more than five persons, including, but not limited to, equipment control rooms and projection booths; and
 - iii) to provide access to raised judges' benches, clerks' stations, speakers' platforms, jury boxes and witness stands or to depressed areas, such as the well of a court.

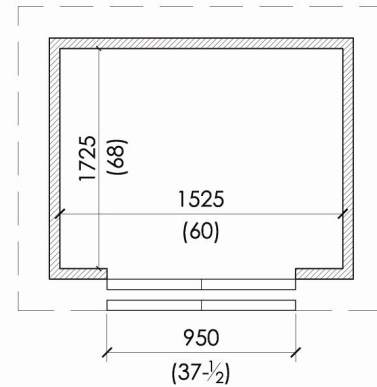

Figure 5.1.16(a)
Minimum Elevator Measurements in Low-use Areas

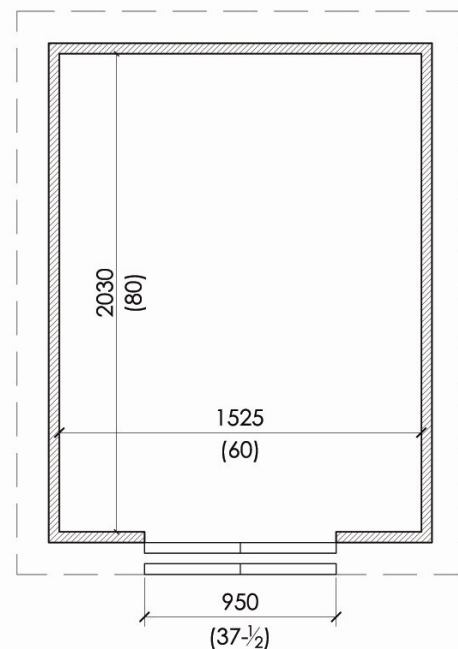

Figure 5.1.16(b)
Minimum Elevator Measurements in High-use Areas



- 3) Accessible elevators shall be on an accessible route complying with section 5.1.4 *Accessible Routes, Paths and Corridors*.
- 4) Accessible elevators shall be identified with signage complying with applicable provisions of section 6.7 *Signage and Wayfinding*.
- 5) Elevators shall be automatic and be provided with a two-way automatic-maintaining levelling device to maintain the floor level to ± 13 mm (1/2 in.).
- 6) Power-operated horizontally sliding car and landing doors opened and closed by automatic means shall be provided.
- 7) The clear width for elevator doors shall be at least 950 mm (37-1/2 in.). In a retrofit situation where it is deemed infeasible to provide a clear elevator door width of 950 mm (37-1/2 in.), the clear elevator door width may be reduced to 915 mm (36 in.).
- 8) Doors shall be provided with a door re-opening device that will function to stop and re-open a car door and an adjacent hoist way door to at least 950 mm (37-1/2 in.), in case the car door is obstructed while closing. This re-opening device shall also be capable of sensing an object or person in the path of a closing door at a nominal 125 mm \pm 25 mm (5 in. \pm 1 in.) and 735 mm \pm 25 mm (29 in. \pm 1 in.) above the floor without requiring contact for activation.
- 9) From the time the doors start to open, a minimum of 4 seconds shall elapse before the door starts to close if it is a hall call, and 3 seconds if it is a car call. This time may be reduced by operation of the door-close button.
- 10) The minimum distance between the walls or between wall and door, excluding return panels, shall not be less than 1725 mm x 1525 mm (68 in. x 60 in.) - **Figure 5.1.16(a)**. In facilities with high public use, such as arenas, libraries or entertainment complexes, the distance between walls or between wall and door shall be 2030 mm x 1525 mm (80 in. x 60 in.) - **Figure 5.1.16(b)**.
- 11) Car controls shall be readily accessible from a wheelchair upon entering an elevator.

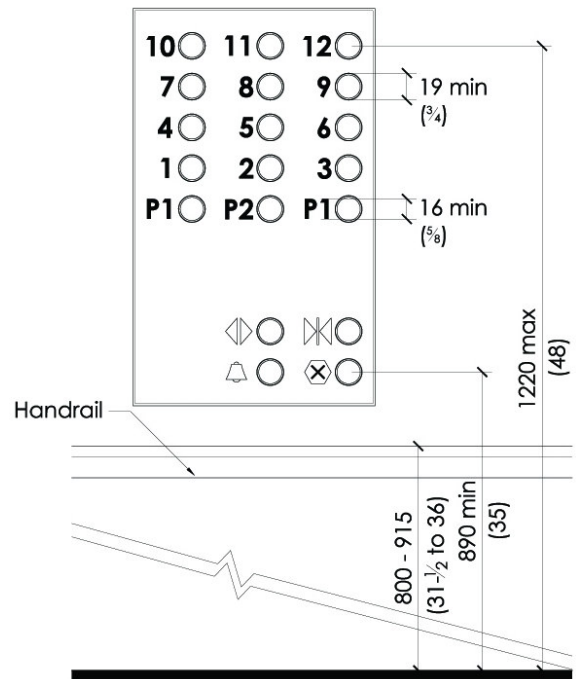

Figure 5.1.16(c)
Control Panel

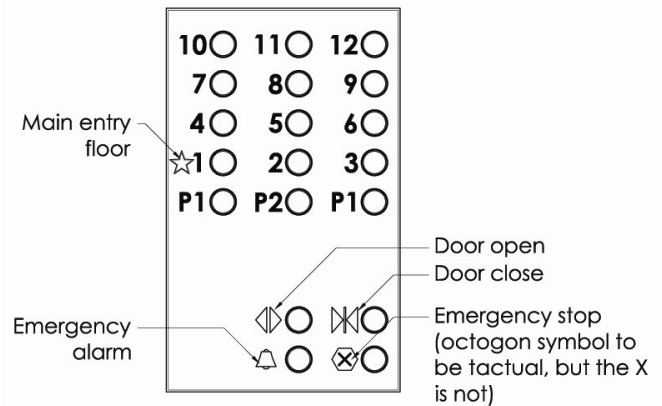

Figure 5.1.16(d)
Tactile Symbols



- 12) Floor register buttons in elevator cabs shall:
 - a) be a minimum 19 mm (3/4 in.) in size and may be raised, flush or recessed. The depth of flush or recessed buttons when they are being operated shall not exceed 10 mm (3/8 in.) - **Figure 5.1.16(c)**; and
 - b) be provided with visual and momentary audible indicators to signal when each call is registered. The visual indicators shall be extinguished when each call is answered.
- 13) All car control buttons shall be designated by Grade 2 Braille characters and by raised standard alphabet characters for letters, Arabic characters for numbers, and standard symbols. Markings shall be a minimum of 16 mm (5/8 in.) high and raised a minimum of 0.75 mm (1/32 in.), placed immediately to the left of the buttons to which they apply - **Figure 5.1.16(d)**.

Exception: Where the call buttons are mechanical, the raised markings may be on the buttons.

- 14) Emergency car controls and door-operating buttons shall be grouped together at the bottom of the control panel. The centre line of the alarm button and the emergency stop switch shall be not less than 890 mm (35 in.) from the floor and no higher than 1220 mm (48 in.). Other controls may be located where it is convenient - **Figure 5.1.16(c)**.
- 15) An indicator shall be provided in the car to show the position of the car in the hoist way, by illuminating the indicator corresponding to the landing at which the car is stopped or passing. Indication characters shall be on a contrasting colour background and a minimum of 16 mm (5/8 in.) high.
- 16) Floors of elevator cabs shall have a firm and slip-resistant surface that permits easy movement of wheelchairs.
- 17) Handrails shall be provided on all non-access walls at a height of 800 mm to 915 mm (31-1/2 in. to 36 in.) with a space of 40 mm to 45 mm (1-1/2 in. to 1-3/4 in.) between the rails and wall.
- 18) The illumination at the car controls and landing sill shall not be less than 100 lux (10 ft-candles).

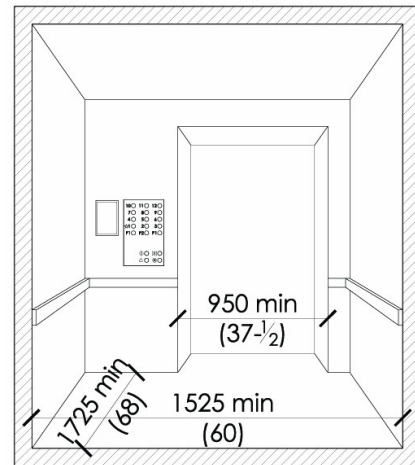
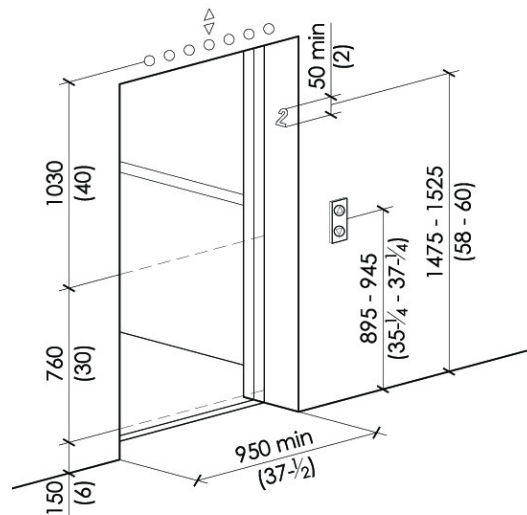

Figure 5.1.16(e)
Elevator Cab



All audible signal shall indicate the passing or location of a floor.
Visual indication shall be provided in a car to show what floor the car is on.

Both visual and audible signals must be used.

Figure 5.1.16(f)
Elevator Entry



- 19) The centre line of hall call buttons shall be between 895 mm (35 in.) and 945 mm (37 in.) above the floor. Buttons shall be a minimum of 19 mm (3/4 in.) in size, mounted one above the other - **Figure 5.1.16(f)**.
- 20) Hall visual indication shall be provided to show each call that is registered and that is extinguished when the call is answered.
- 21) Hall or in-car lanterns shall be provided. The centre line of the fixture shall be a minimum of 1940 mm (76-1/2 in.) above the floor. An audible signal shall be provided when the elevator stops at the landing. Visual elements shall be a minimum of 50 mm (2 in.) in the smallest direction - **Figure 5.1.16(f)**.
- 22) All elevator hoist way entrances shall have raised Arabic numerals and Braille floor designations provided on both jambs. The characters shall be a minimum of 50 mm (2 in.) high and at least 0.75 mm (1/32 in.) thick shall be placed on both sides of the doorjamb, with the centre line between 1475 mm and 1550 mm (58 in. and 61 in.) from the floor.
- 23) As the car stops at a floor, the floor number and direction of travel shall be announced using voice-annunciation technology.
- 24) Elevators shall be linked by an emergency call system to a monitored location within the facility, with two-way communication ability. The highest operable portion of the 2-way communication system shall be a maximum of 1220 mm (48 in.) from the floor of the car. It shall be identified by a raised symbol and lettering located adjacent to the device. The symbol shall be a minimum of 38 mm (1-1/2 in.) high and raised a minimum of 0.75 mm (1/32 in.). Permanently attached plates are acceptable. If the system uses a handset, then the length of the cord from the panel to the handset shall be at least 735 mm (29 in.). Additionally, the handset shall be equipped with a receiver that generates a magnetic field in the area of the receiver cap, and the handset shall have a volume control and shall comply with CSA Standard T515. If the system is located in a dosed compartment, the compartment door and hardware shall conform to section 5.4.1 *Controls and Operating Mechanisms*. The emergency intercommunication system shall not require voice communication.



- 25) Lighting in elevator cabs shall be at least 100 lux (9.2 ft-candles), measured at the floor level and at the same lighting level as the adjacent lobby space.
- 26) Mirror shall not be used within elevator cabs as a finish material on the wall opposite the door, unless the area of the elevator makes it difficult for a person in a wheelchair to turn around to view the door.
- 27) Floor finishes within elevator cabs shall comply with section 5.1.2 *Ground and Floor Surfaces*.
- 28) Elevator doors shall incorporate pronounced colour contrast, to differentiate them from the surrounding environment.
- 29) There shall be a pronounced colour contrast between the car sill and the facility floor.

Related Sections

- 5.1.1 Space and Reach Requirements
- 5.1.2 Ground and Floor Surfaces
- 5.1.9 Doors
- 5.1.14 Handrails
- 5.1.17 Platform Lifts
- 5.4.1 Controls and Operating Mechanisms
- 6.1 Glare and Light Sources
- 6.2 Lighting
- 6.3 Materials and Finishes
- 6.4 Texture and Colour
- 6.7 Signage and Wayfinding
- 7.2 Public Address Systems





Barriers and Obstacles

Platform lifts have historically been considered an accessibility requirement. However, these lifts tend to segregate persons with disabilities and limit space at entrance and stair locations. Independent access is often compromised, as access to platform lifts is controlled by key operation. Whenever possible, grading or integrated elevator access should be incorporated to avoid the use of lifts.

If there are no suitable alternatives, lifts must be selected to permit the use of scooters, as well as wheelchairs.

Design Requirements

- 1) Platform lifts may only be used in lieu of an elevator or ramp where allowable under section 5.1.16 *Elevators* - **Figures 5.1.17(a), 5.1.17(b), and 5.1.17(c)**.
- 2) Accessible platform lifts shall
 - a) be on an accessible route complying with 5.1.4 *Accessible Routes, Paths and Corridors*;
 - b) be identified with signage complying with applicable provisions of section 6.7 *Signage and Wayfinding*;
 - c) comply with CSA standard CAN/CSA B355; and
 - d) facilitate unassisted entry, operation, and exit from the lift.
- 3) The platform size shall be no less than 1220 mm x 1525 mm (48 in. x 60 in.).
- 4) The doors to the platform lift shall comply with section 5.1.9 *Doors*.
- 5) Controls and operating mechanisms shall comply with section 5.1.1 *Space and Reach Requirements*.
- 6) Platform lifts shall be linked by an emergency call system to a monitored location within the facility, with two-way communication ability. The highest operable portion of the two-way communication system shall be a maximum of 1220 mm (48 in.) from the floor of the car. If the system uses a handset, then the length of the cord from the panel to the handset shall be at least 735 mm (29 in.). If the system is located in a closed compartment, the compartment door and hardware shall conform to section 5.1.4 *Accessible Routes, Paths and Corridors*.
- 7) Floor finishes within platform lifts shall comply with section 5.1.2 *Ground and Floor Surfaces* and section 6.3 *Materials and Finishes*.

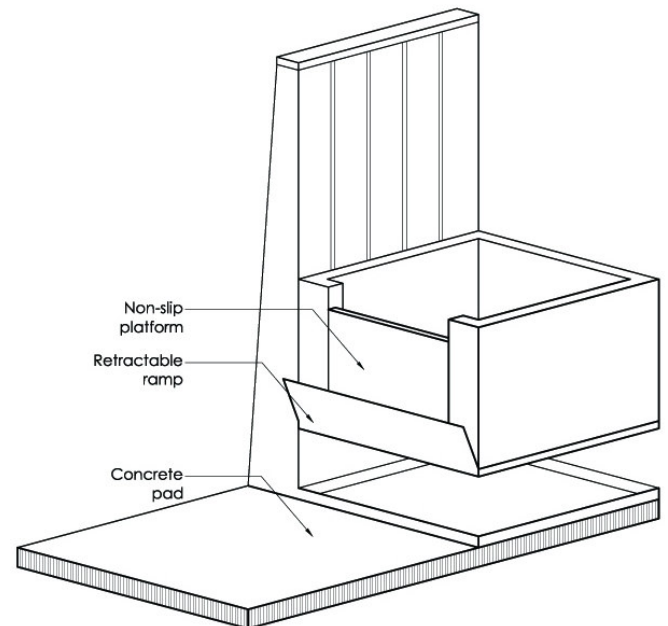

Figure 5.1.17(a)
Vertical Platform Lift

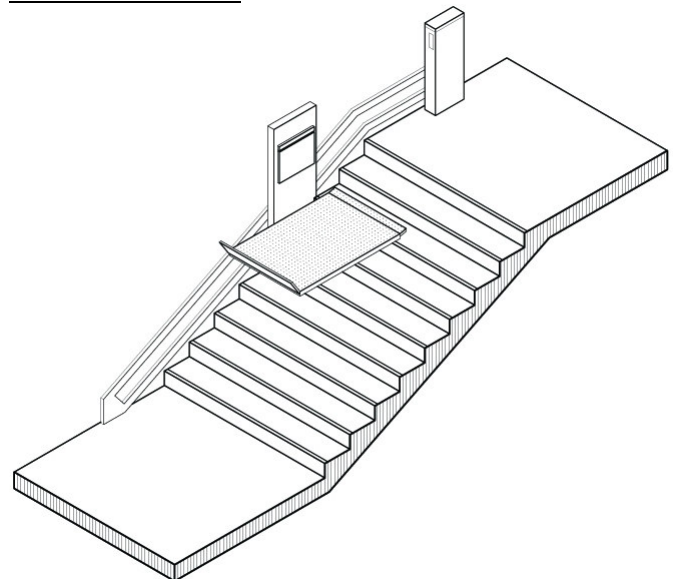

Figure 5.1.17(b)
Inclined Platform Stair-Lift



Related Sections

- 5.1.1 Space and Reach Requirements
- 5.1.2 Ground and Floor Surfaces
- 5.1.9 Doors
- 5.1.14 Handrails
- 5.1.16 Elevators
- 5.4.1 Controls and Operating Mechanisms
- 5.2.1 Glare and Light Sources
- 5.2.2 Lighting
- 5.2.3 Materials and Finishes
- 5.2.5 Texture and Colour
- 5.2.7 Signage and Wayfinding
- 5.3.2 Public Address Systems

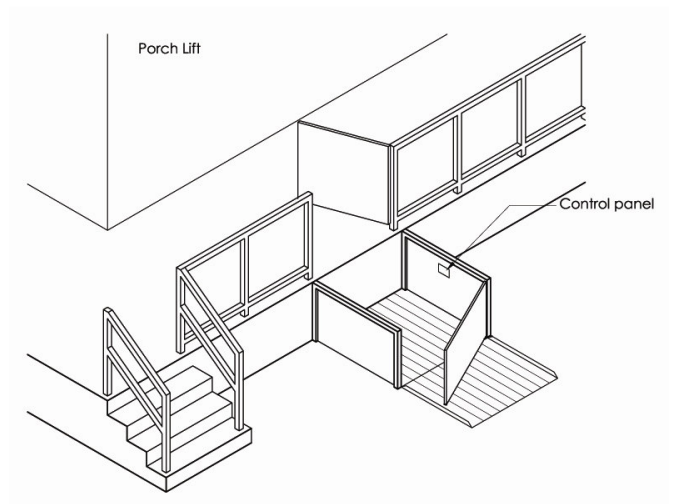

Figure 5.1.17(c)
Exterior Lift



Washrooms have traditionally posed a significant barrier to people using physical aids.

This section deals with the design and provision of requirements for adequate universal access into areas provided for personal hygiene, and systems provided therein.

5.2.

- 1 Toilet and Bathing Facilities
- 2 Toilet Stalls
- 3 Toilets
- 4 Lavatories
- 5 Urinals
- 6 Individual Washrooms
- 7 Washroom Accessories
- 8 Bathtubs
- 9 Shower Stalls
- 10 Grab Bars





Barriers and Obstacles

Toilet and bathing facilities cover a wide range of issues and considerations with regard to public and common use. A public washroom might include baby change tables, sanitary product vending machines, urinals, etc., and these may be provided in many variations and combinations.

While many basic principles of access need to be considered (see **Related Sections**) specific problems do present themselves.

- Safety; bathrooms are notorious places for falls to occur. As a result the following should be considered:
 - emergency call buttons;
 - access of emergency crews (doors should swing out);
 - slip-resistant surfaces (due to additional moisture);
 - sufficient and safe transfer space (from mobility aid to fixture); and
 - water temperature and pressure.
- Signage; clear and understandable signage is important to access as washrooms serve a universal need.
- Flexibility; an available washroom facility for either gender that is accessible.

Design Requirements

- 1) Where public toilet and bathing facilities are provided they shall comply with this section:
 - a) Accessible toilet and bathing facilities shall be located on an accessible route.
 - b) Signage at washroom entrances shall:
 - i) comply with section 6.7 Signage and Wayfinding;
 - ii) if there is no door, be mounted on both sides of the entrance opening; and
 - iii) if the washroom is not accessible, indicate the location of the nearest accessible washroom.
 - c) A clear floor space shall be provided:
 - i) at the entrance or door complying with section 5.1.9 Doors; and
 - ii) at the front of the accessible toilet or bathing stalls to allow a wheelchair with a 1930 mm (6 ft. 4 in.) turning radius to make a 180 degree turn - **Figure 5.2.1(a)**
 - d) Provide for accessible fixtures and accessories (see section 5.2.7 Washroom Accessories).

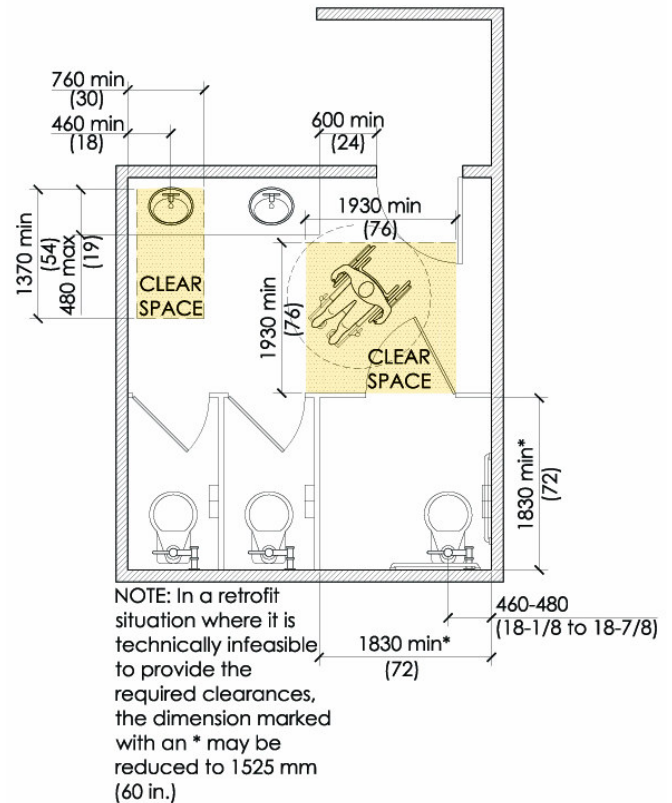

Figure 5.2.1(a)
Washroom Dimensions

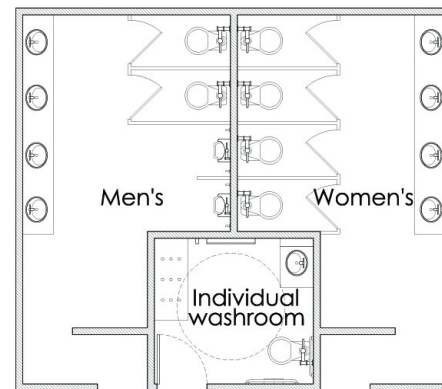

Figure 5.2.1(b)
Washroom Dimensions



- e) Wherever possible, locate barrier free stalls:
 - i) in the most direct route from the entrance with the least number of turns; and
 - ii) closest to the entrance to avoid having to move through a crowded washroom.
- 2) In a retrofit situation where it is deemed infeasible to make existing public or common use toilet or bathing facilities accessible, the installation of at least one:
 - a) toilet stall in accordance with section 5.2.2 *Toilet Stalls* or individual washroom in accordance with section 5.2.6 *Individual Washrooms* (if the individual washroom is within 45 m (147 ft. 8 in.), and on the same level as the existing washroom;
 - b) lavatory in accordance with section 5.2.4 *Lavatories*;
 - c) urinal in accordance with section 5.2.5 *Urinals*;
 - d) washroom accessory (e.g., hand dryer) in accordance with section 5.2.7 *Washroom Accessories*;
 - e) bathtub in accordance with 5.2.8 *Bathtubs*;
 - f) shower stall in accordance with section 5.2.9 *Shower Stalls* (where applicable);
 will be permitted in lieu of modifying existing toilet facilities to be accessible.
- 3) Public washrooms shall be provided under the following conditions:
 - a) Where a common or public use washroom contains four or more toilets and/or urinal fixtures, an individual washroom complying with section 5.2.6 *Individual Washrooms* shall also be provided, in the same area - **Figure 5.2.1(b)**.
 - b) An individual washroom provided in lieu of barrier free stalls in the common or public use washrooms, shall:
 - i) not be further than 45m (147 ft. 8 in.) from the common or public use washrooms - **Figures 5.2.1(c)** and **5.2.1(d)**;
 - ii) be connected by an accessible route; and
 - iii) be on the same level as the public use washrooms.

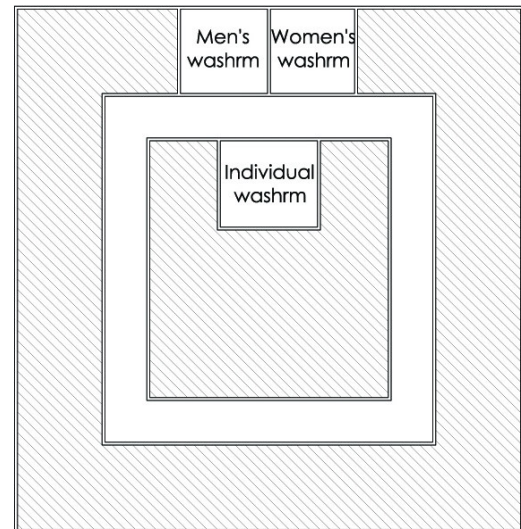

Figure 5.2.1(c)
Preferred Individual Washroom Location

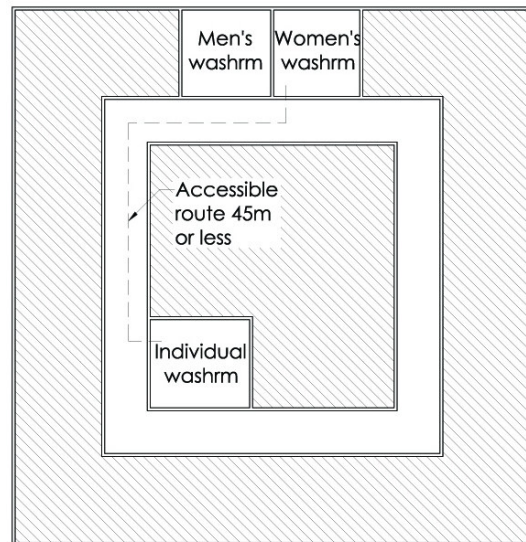

Figure 5.2.1(d)
Acceptable Individual Washroom Location



- c) Where there is more than one set of common or public use washrooms on a floor, provide an individual washroom complying with section 5.2.6 *Individual Washrooms* for every two sets - **Figure 5.2.1(e)**.
- d) Washrooms provided for the use of occupants of specific spaces (e.g., a private toilet room for the occupant of a private office) shall be adaptable.
- e) For single unit items (toilet or bathing units) within a clustered configuration, at least 5% but not less than one unit shall comply with this section.

Exception: portable toilet units at construction sites used exclusively by construction personnel.

- f) Where an individual washroom is not visible from the public or common use washrooms, directional signs complying with section 6.7 *Signage and Wayfinding* shall be provided.

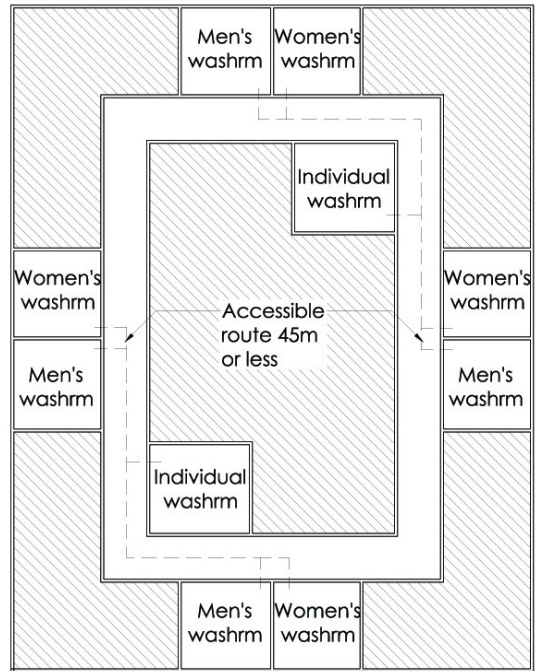

Figure 5.2.1(e)
Acceptable Individual Washroom Location

Related Sections

- 5.1.1 Space and Reach Requirements
- 5.1.2 Ground and Floor Surfaces
- 5.1.3 Protruding Objects
- 5.1.9 Doors
- 5.2.2 Toilet Stalls
- 5.2.3 Toilets
- 5.2.4 Lavatories
- 5.2.5 Urinals
- 5.2.6 Individual Washrooms
- 5.2.7 Washroom Accessories
- 5.2.8 Bathtubs
- 5.2.9 Shower Stalls
- 6.7 Signage and Wayfinding





Barriers and Obstacles

The design of an accessible stall is primarily determined by the manoeuvrability of a wheelchair. A few issues that must be considered are:

- the mobility and turning radii of such aides;
- the swing of the door (usually outward) and the ease with which someone can close the door behind them;
- how a person transfers onto the toilet fixture; and
- access in case of an emergency.

Design Requirements

Where accessible toilet stalls are provided, they shall comply with this section:

- 1) Accessible toilet stalls shall have:
 - a) internal dimensions of at least 1830 mm x 1830 mm (72 in. x 72 in.) - **Figure 5.2.2(a)**, and **5.2.2(b)** - except where an individual washroom is provided, then the stall can be 1525 mm x 1525 mm (60 in. x 60 in.);
 - b) a toilet complying with section 5.2.3 *Toilets* including types, dimensions, heights, etc. of:
 - i) fixture;
 - ii) flush controls (sensor activated is preferred);
 - iii) grab bars; and
 - iv) toilet paper dispenser;
 - c) a hook on a side wall – preferably on a solid wall:
 - i) mounted not more than 1220 mm (48 in.) above the floor; and
 - ii) projecting no more than 40 mm (1-1/2 in.) from the wall.
 - d) accessories positioned in such a manner so as not to obstruct movement or use of the grab bars.

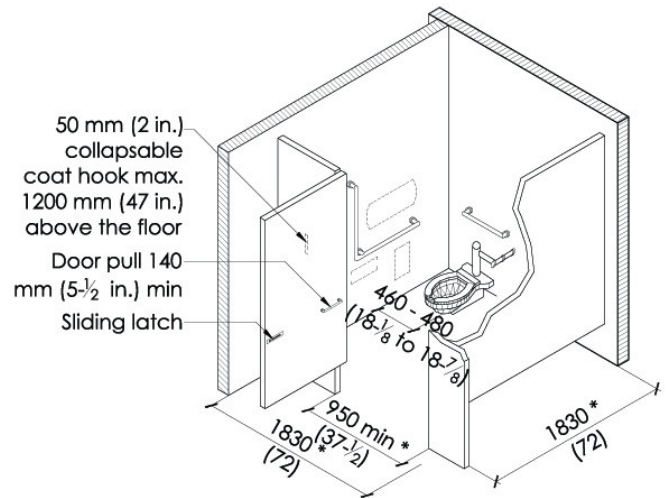

NOTE: When an individual washroom is provided, the accessible stall can be 1524x1524 (60x60 in.) In a retrofit situation where it is technically infeasible to provide the required clearances, the dimension marked with an * may be reduced. Refer to 4.2.2 - Design Requirements

Figure 5.2.2(a)
Accessible Toilet Stall

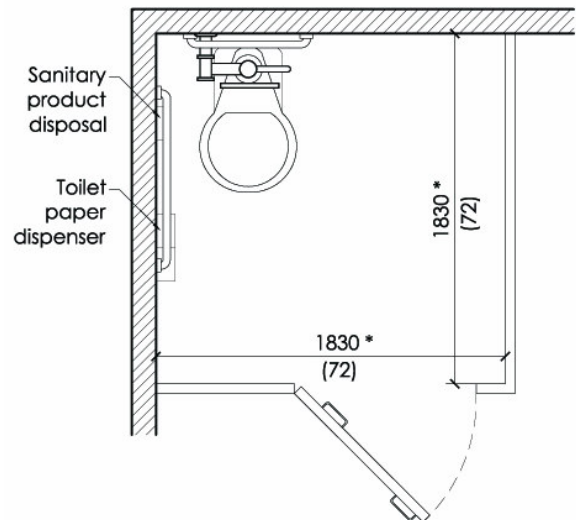

NOTE: When an individual washroom is provided, the accessible stall can be 1524x1524 (60x60 in.) In a retrofit situation where it is technically infeasible to provide the required clearances, the dimension marked with an * may be reduced. Refer to 4.2.2 - Design Requirements

Figure 5.2.2(b)
Accessible Toilet Stall



- 2) The number of accessible toilet stalls designated to accommodate persons with disabilities shall comply with **Table 5.2.2**.
- 3) Where more than one accessible toilet stall is provided within a washroom, the stalls shall be configured with the transfer space (e.g., the open space beside the stall) on the opposite sides of the toilet fixtures.
- 4) Where an individual washroom is provided in addition to an accessible stall:
 - a) provide the transfer space in the accessible stall opposite to that provided in the individual washroom.
 - b) the accessible stall can be 1525 mm x 1525 mm (60 in. x 60 in.).
 - c) be on an accessible route complying with section 5.1.4 *Accessible Routes, Paths and Corridors*.
- 5) Toilet stall doors shall:
 - a) provide a clear opening of at least 950 mm (37-1/2 in.) with the door in the open position;
 - b) be aligned with the transfer space adjacent to the toilet;
 - c) swing outward, unless additional space is provided within the stall for the door swing;
 - d) have a “D”-type door pull at least 140 mm (5-1/2 in.) long, mounted horizontally on the inside of an out-swinging door:
 - i) with its centre line located 200 mm to 300 mm (8 in. to 12 in.) from the hinge edge; and
 - ii) at a height of 810 mm to 1000 mm (32 in. to 39 in.) from the floor;
 - e) have a “D”-type door pull at least 140 mm (5-1/2 in.) long, mounted horizontally on the outside:
 - i) with its centre line located 125 mm to 220 mm (5 in. to 8-1/2 in.) from the latch edge of the door; and
 - ii) at a height of 810 mm to 1000 mm (32 in. to 39 in.) from the floor;

# of toilet stalls within the washroom	Required # of <u>accessible</u> toilet stalls
1-5	1
More than 5	2

Table 5.2.2
Number of Accessible Toilet Stalls



- f) be self-closing so that when at rest, the door will be ajar to an extent not more than 50 mm (2 in.) beyond the jamb;
- g) be latched from the inside by a device that complies with section 5.4.1 *Controls and Operating Mechanisms*.
- h) have a clear area that complies with section 5.2.1. *Toilet and Bathing Facilities* point 1 (c).

Related Sections

- 5.1.1 Space and Reach Requirements
- 5.1.3 Protruding Objects
- 5.1.9 Doors
- 5.2.3 Toilets
- 5.2.7 Washroom Accessories
- 5.2.10 Grab Bars
- 5.2.4 Texture and Colour
- 5.4.1 Controls and Operating Mechanisms





Barriers and Obstacles

The accessibility of toilets requires that consideration be given to:

- easy access to flushing mechanisms;
- that such mechanisms be easy to operate (automatic flush controls are preferred);
- the height of the seat above the floor;
- strategic placement of grab bars; and
- sufficient transfer space.

Design Requirements

- 1) A toilet fixture shall have:
 - a) the top of the seat between 400 mm and 460 mm (15-3/4 in. and 18 in.) from the floor - **Figure 5.2.3(a)**;
 - b) a seat that is not spring activated;
 - c) a back support where there is no seat lid or tank; and
 - d) where there is a tank, a tank lid that is securely attached.
- 2) A toilet shall:
 - a) be located with its centre line 460 mm to 480 mm (18 in. to 19 in.) from an adjacent wall - **Figure 5.2.3(b)**; and
 - b) have a clear transfer space at least 900 mm (35-1/2 in.) wide by 1525 mm (60 in.) long on its open side, the width measured from the edge of the toilet bowl - **Figure 5.2.3(b)**.
- 3) Flush controls shall:
 - a) be automatically activated;
 - b) where automatically activated, be supplemented with a manually operated control, in compliance with section 5.4.1 *Controls and Operating Mechanisms* or;
 - c) be hand-operated by a lever that
 - i) complies with section 5.4.1 *Controls and Operating Mechanisms*; and
 - ii) is located at the transfer side of the toilet.

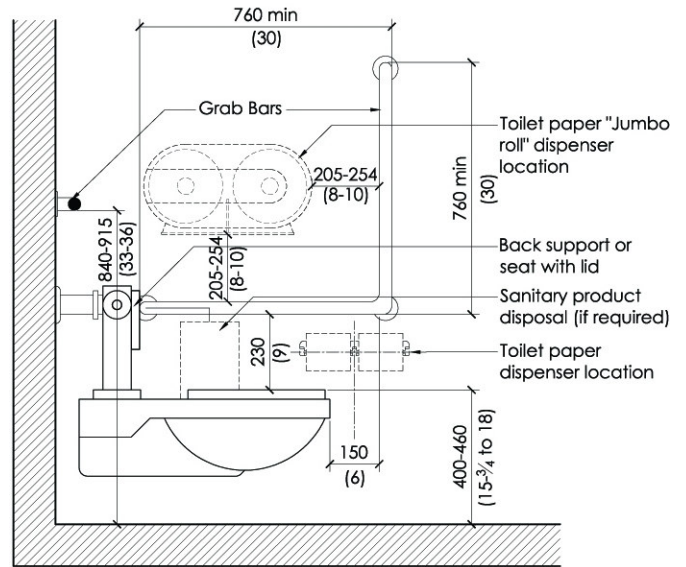

Figure 5.2.3(a)
Grab Bar and Toilet Paper Dispenser Configuration

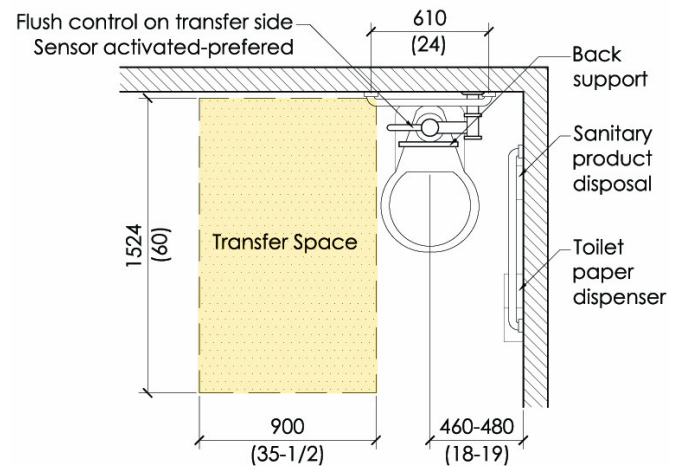

Figure 5.2.3(b)
Toilet Stall Transfer Space Plan



- 4) Two grab bars that comply with section 5.2.10 *Grab Bars* shall be mounted horizontally at a height of 750 mm to 850 mm (29-1/2 in. to 33-1/2 in.) from the floor, as follows:
 - a) One on the wall adjacent to the toilet:
 - i) L-shaped where each leg is 760 mm (30 in.) and at 90° to each other;
 - ii) where the vertical leg is 150 mm (6 in.) in front of the toilet bowl; and
 - iii) where the horizontal component is 230 mm (9 in.) above the seat;
 - b) One on the rear wall:
 - i) centred with the toilet;
 - ii) at least 610 mm (24 in.) long;
 - iii) 840 mm to 915 mm (33 in. to 36 in.) above the floor; and
 - iv) where there is a water tank, be mounted 150 mm (6 in.) above the tank.
- 5) A toilet paper dispenser shall be:
 - a) wall mounted;
 - b) located so that the dispensing of the paper is in line with the front of the toilet seat;
 - c) located below the grab bar – and so the paper dispenses at a height between 610 mm and 700 mm (24 in. and 27-1/2 in.) above the finished floor
 - d) of a contrasting colour to the wall;
 - e) recessed into the wall wherever possible; and
 - f) where bulk dispensers are used recessed models are preferred. Bulk dispensers that interfere with the effective use of the grab bars are not recommended.

Related Sections

- 5.1.1 Space and Reach Requirements
- 5.2.2 Toilet Stalls
- 5.2.10 Grab Bars
- 5.4.1 Controls and Operating Mechanisms
- 6.4 Texture and Colour



Barriers and Obstacles

The accessibility of lavatories requires that consideration be given to:

- easy-to-use operating mechanisms (e.g., sensor activated technology is preferred for items such as faucets and soap and paper dispensers);
- lower counters for persons in wheelchairs or scooters; and
- insulation of hot water pipes where persons in wheelchairs or scooters may burn their legs (insulation needs to allow for maintenance).

Design Requirements

All lavatories shall comply with this section. Lavatories shall:

- 1) be on an accessible route complying with section 5.1.4 *Accessible Routes, Paths and Corridors*;
- 2) be mounted so that the minimum distance between the centre line of the fixture and the side wall is 460 mm (18 in.) - **Figure 5.2.1(a)** in section 5.2.1 *Toilet and Bathing Facilities*;
- 3) have the top located between 820 mm and 840 mm (32-1/4 in. and 33 in.) from the floor; have a knee space of at least 760 mm (30 in.) wide - **Figure 5.2.4(a)**;
 - a) 685 mm high (27 in.) at a point 205 mm (8 in.) back from the front edge - **Figure 5.2.4(a)**; and
 - b) 230 mm (9 in.) high over the distance from a point 280 mm (11 in.) to a point 430 mm (17 in.) back from the front edge - **Figure 5.2.4(a)**;
- 4) in a retrofit situation where it is deemed infeasible to have all lavatories comply with this section, at least one lavatory in each accessible washroom shall comply.
- 5) have a minimum clear floor space 760 mm (30 in.) wide and 1370 mm (54 in.) deep, of which a maximum of 430 mm (17 in.) in depth may be under the lavatory;
- 6) have hot water and drain pipes insulated if they abut the clearances noted above, or have the water temperature limited to a maximum of 43°C (100°F). Wherever possible, water temperature should be controlled to reduce need for additional controls;

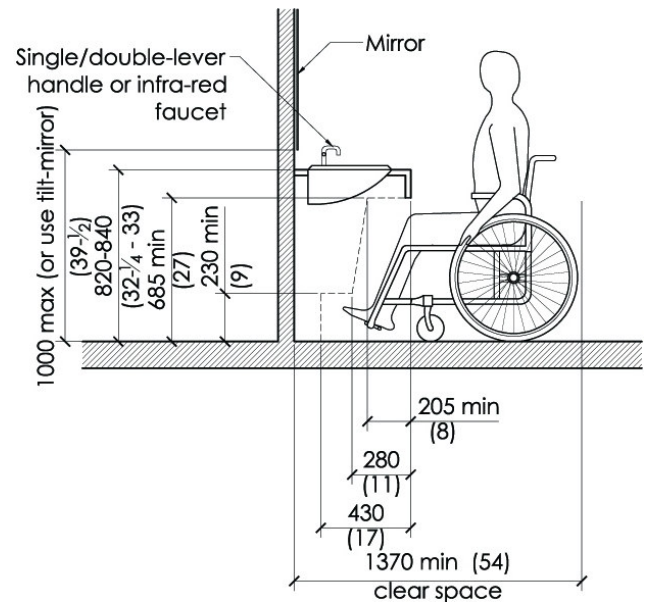

Figure 5.2.4(a)
Lavatory Criteria



- 7) have soap and towel dispensers that are:
 - a) located to be accessible to persons in wheelchairs (e.g., not having to reach over the lavatory to access the devices);
 - b) located so that the dispensing height is not more than 1200 mm (47-1/4 in.) above the floor (see section 5.2.7 *Washroom Accessories*);
 - c) colour-contrasted from the surrounding environment; and
 - d) in compliance with section 5.4.1 *Controls and Operating Mechanisms*.
- 8) Faucets and other controls shall:
 - a) have handles of the lever style or, preferably, be electronically controlled; and
 - b) be located so that the distance from the centre line of the faucet to the edge of the basin, or where the basin is mounted in a vanity, to the front edge of the vanity is not more than 485 mm (19 in.).
- 9) Shelves or other projections above lavatories shall be located so they will not present a hazard to persons with a visual disability.
- 10) Where mirrors are provided at lavatories or vanity units, they shall comply with section 5.2.7 *Washroom Accessories*.
- 11) Wherever possible provide sensor-activated technology to reduce the need for operating mechanisms that require strength manoeuvres or reach extensions (e.g. soap and paper dispensers, hand driers).

Related Sections

- 5.1.1 Space and Reach Requirements
- 5.4.1 Controls and Operating Mechanisms
- 6.4 Texture and Colour



Barriers and Obstacles

The accessibility of urinals requires that consideration be given to:

- floor space in front of the fixture for manoeuvrability;
- grab bars for persons to pull themselves up or steady themselves;
- easy access to flushing mechanisms and that those such mechanisms be easy to operate, (e.g., levered flush controls, however automatic flush controls are preferred); and
- floor-mounted urinals, which make it easier for persons to drain personal reservoirs.

Design Requirements

Where urinals are provided in an accessible toilet or bathing facility, they shall comply with this section.

Urinals shall:

- 1) be floor-mounted, with the rim level at the finished floor (preferred); or
- 2) be wall-mounted with an elongated rim located between 488 mm and 510 mm (19-1/4 in. and 20 in.) above the finished floor (for persons in wheel chairs) - **Figure 5.2.5(a)**;
- 3) have a clear floor space of 760 mm by 1370 mm (30 in. by 54 in.) in front of the urinal to allow for a forward approach. This clear space shall adjoin or overlap an accessible route and shall comply with section 5.1.1 *Space and Reach Requirements*;
- 4) where privacy screens are provided:
 - a) have at least 800 mm (31-1/2 in.) of clearance between them - **Figure 5.2.5(b)**; and
 - b) they shall incorporate a pronounced colour contrast, to differentiate them from the surrounding environment;
- 5) have grab bars installed on each side, vertically mounted, not less than 610 mm (24 in.) long, with the centre line 900 mm to 950 mm (35-1/2 in. to 37 in.) above the floor, and located not more than 380 mm (15 in.) from the centre line of the urinal. Grab bars shall comply with section 5.2.10 *Grab Bars*;
- 6) have flush controls that are sensor activated or hand operated with a lever style control, mounted at no more than 1120 mm (44 in.) above the finished floor, and shall comply with section 5.4.1 *Controls and Operating Mechanisms*; and

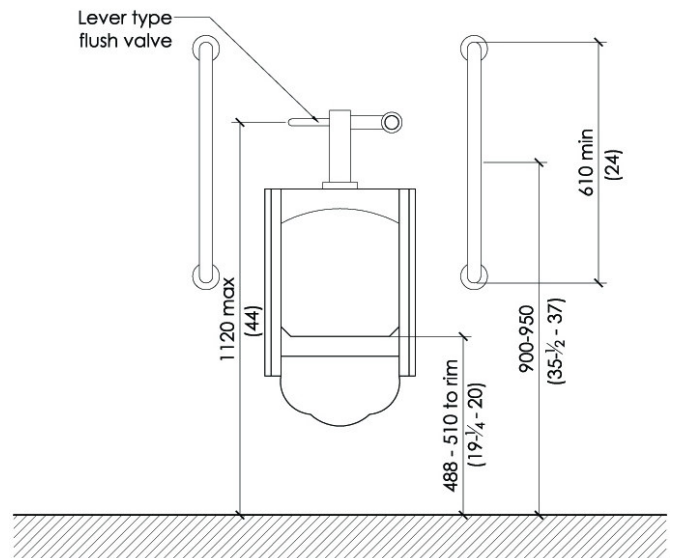

Figure 5.2.5(a)

Urinal

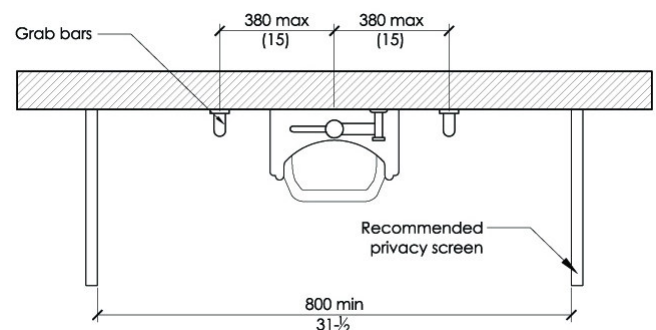

Figure 5.2.5(b)

Urinal



- 7) be provided with markers for the visually impaired:
 - a) at floor-mounted models, provide a highly contrasting floor, or a contrasting coloured edge strip; and
 - b) each urinal shall be identified with a vertical marker that:
 - i) is centred on the urinal;
 - ii) extends 150 mm (6 in.) minimum above the top of the urinals;
 - iii) is no less than 50 mm (2 in.) wide, and raised at least 3 mm (1/8 in.) above the surrounding wall surface; and
 - iv) is colour contrasted no less than 70% with the back wall.

Related Sections

- 5.1.1 Space and Reach Requirements
- 5.4.1 Controls and Operating Mechanisms
- 6.4 Texture and Colour



Barriers and Obstacles

The provision of a separate and accessible individual washroom is advantageous in a number of instances such as

- parents with small children of the opposite gender;
- persons with disabilities with an assistant of the opposite gender; and
- persons who feel comfortable with additional privacy (e.g., breastfeeding mothers, self-conscious users, etc.).

Design Requirements

- 1) If four or more water closets are required for each gender by the Ontario Building Code, at least one individual washroom shall be provided.
- 2) Where only one water closet is required for each sex by the Ontario Building Code, manually activated power door operators and baby change tables are suggested, but not required.
- 3) Where an individual washroom containing a single toilet and a lavatory is provided - **Figures 5.2.6(a)**, and **5.2.6(b)** - it shall have:
 - a) a toilet that complies with section 5.2.3 Toilets;
 - b) a lavatory that complies with section 5.2.4 Lavatories;
 - c) a door that:
 - i) complies with section 5.1.9 Doors;
 - ii) can be unlocked from the outside in emergency situations;
 - iii) has a manually activated power operator that complies with section 5.1.9 Doors (it is preferable to provide a side approach to the button);
 - d) a shelf or a counter at least 200 mm by 400 mm (8 in. by 15-3/4 in.);
 - e) grab bars that comply with section 5.2.10 Grab Bars;
 - f) a coat hook mounted on a side wall:
 - i) at a height not more than 1200 mm (47 in.) from the floor; and
 - ii) protruding not more than 40 mm (1-1/2 in.) from the wall; and

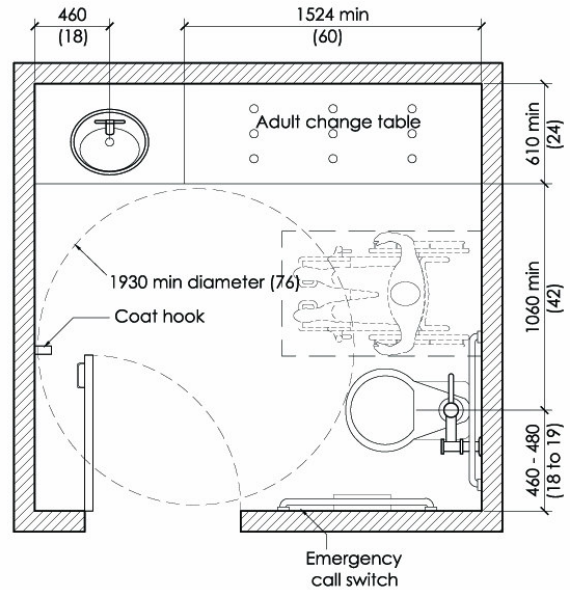

Figure 5.2.6(a)
Individual Washroom with Fix Adult Change Table

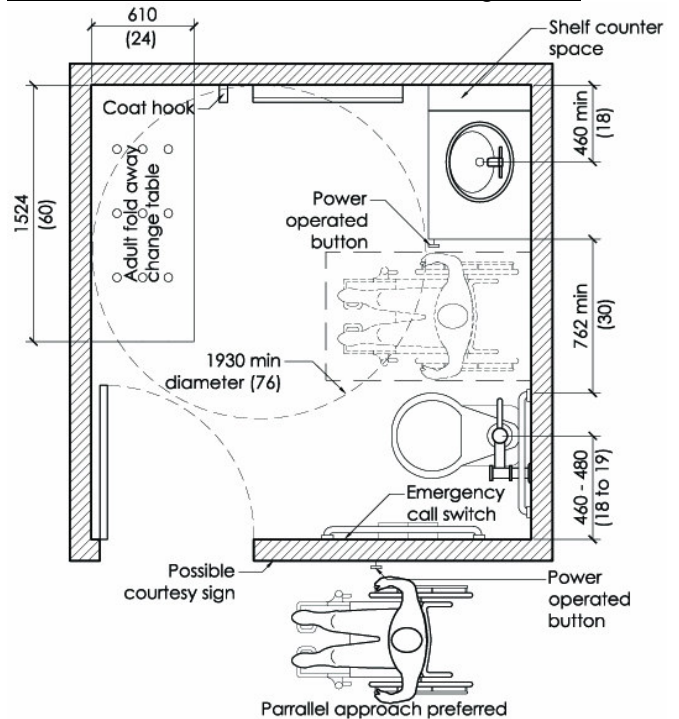

Figure 5.2.6(b)
Individual Washroom with Fold Away Change Table



- g) a baby change table and other necessary accessories that comply with section 5.2.7 *Washroom Accessories*.
- 4) Where individual washrooms are provided the following additional accessories are recommended:
 - a) an adult change table that complies with section 5.2.7 *Washroom Accessories* may be provided in larger public buildings, for persons that are too large for a traditional baby change table; and
 - b) an emergency call system is recommended in larger public buildings (e.g., recreational facilities) linked to a central location (e.g., security desk, information desk, switchboard).
- 5) Where individual washrooms are provided signage complying with applicable provisions of section 6.7 *Signage and Wayfinding* should be provided.
 - a) Signs should indicate:
 - i) intended gender (male/female) and/or family symbols; and
 - ii) the International Symbol of Access.
 - b) A courtesy sign is recommended, requesting that priority be afforded to persons in wheelchairs/scooters.
- 6) Where more than one individual washroom is provided in a different location it is preferable to design washrooms with transfer spaces on alternating sides.

Related Sections

- 5.1.1 Space and Reach Requirements
- 5.1.2 Ground and Floor Surfaces
- 5.1.3 Protruding Objects
- 5.1.9 Doors
- 5.2.3 Toilets
- 5.2.4 Lavatories
- 5.2.7 Washroom Accessories
- 5.2.10 Grab Bars
- 5.4.1 Controls and Operating Mechanisms
- 6.7 Signage and Wayfinding



Barriers and Obstacles

The accessibility of washroom accessories requires that consideration be given to:

- hand strength and dexterity to operate mechanisms;
- space and reach requirements; and
- co-ordination difficulties if 2 hands are required to operate mechanism.

Refer to section 5.4.1 *Controls and Operating Mechanisms* for further details.

Design Requirements

Where washroom accessories are provided they shall comply with this section (except those located in toilet stalls as specified in section 5.2.2 *Toilet Stalls*) - **Figure 5.2.7(a)**.

- 1) The operable portions and controls of each type of washroom accessory shall comply with section 5.4.1 *Controls and Operating Mechanisms*.
- 2) **Mirrors:**
 - a) shall be mounted with the bottom edge not more than 1000 mm (39-1/2 in.) above the floor;
 - b) are preferred if full length;
 - c) that are tilted are acceptable only in cases of retrofit to an existing facility; and
 - d) should not be installed where they would reflect into the path of travel.
- 3) **Soap dispensers:**
 - a) at lavatories shall comply with relevant information of section 5.2.4 *Lavatories*;
 - b) at shower stalls shall not be mounted higher than 1100 mm (43-1/4 in.) above the floor; and
 - c) shall be sensor activated or operable with one hand to dispense soap on the palm of that hand.
- 4) **Baby change tables** shall:
 - a) be located with the change surface not more than 840 mm (33 in.) above the finished floor;
 - b) incorporate an adjacent clear floor space not less than 760 mm by 1370 mm (30 in. by 54 in.);
 - c) be not less than 500 mm (19-3/4 in.) wide and 800 mm (31-1/2 in.) long;
 - d) be capable of supporting a static load of 136 kg (300 lbs.);

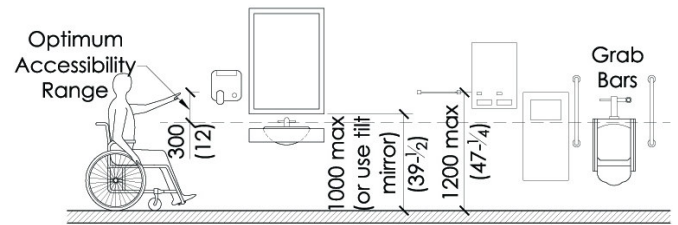

Figure 5.2.7(a)
Washroom Accessories



- e) be provided with safety straps;
 - f) be located on an accessible route in compliance with section 5.1.4 *Accessible Routes, Paths and Corridors*; and
 - g) if of the fold-down type, have no operable portions higher than 1200 mm (47 in.).
- 5) **Adult change tables** shall:
- a) be at least 610 mm (24 in.) wide and 1525 mm (60 in.) in length;
 - b) be mounted 400 mm to 500 mm (15-3/4 in. to 19-3/4 in.) above the finished floor;
 - c) have a smooth surface, that allows for drainage;
 - d) be able to support a static load of 136 kg (300 lbs);
 - e) incorporate an adjacent clear floor space not less than 760 mm by 1370 mm (30 in. by 54 in.);
 - f) be located on an accessible route in compliance with section 5.1.4 *Accessible Routes, Paths and Corridors*; and
 - g) if of the fold-down type, have no operable portions higher than 1115 mm (44 in.) above the finished floor.
- 6) In a retrofit situation where it is deemed infeasible to make all washroom accessories comply with this section, at least one of each type of washroom accessory shall comply in all accessible washroom facilities.

Related Sections

- 5.1.1 Space and Reach Requirements
- 5.1.3 Protruding Objects
- 5.4.1 Controls and Operating Mechanisms
- 6.4 Texture and Colour



Barriers and Obstacles

The accessibility of bathtubs requires that consideration be given to:

- slippery surfaces;
- hand strength and dexterity of the user to operate (faucets, soap dispensers, etc.); and
- stability and balance on entering and exiting (grab bars, etc.)

Design Requirements

Where bathtubs are provided, they shall comply with this section.

- 1) Access to bathtubs shall:
 - a) be provided on an accessible route complying with section 5.1.4 *Accessible Routes, Paths and Corridors*; and
 - b) have a clear floor space at least 760 mm (30 in.) along the length of the bathtub (the lavatory can encroach a maximum of 305 mm (12 in.) into this space provided there is clear knee space and toe space under the lavatory.
 - c) Grab bars that comply with section 5.2.10 *Grab Bars* shall be mounted as follows:
 - i) One horizontally along the length of the bathtub - **Figure 5.2.8(a)**:
 - at least 1220 mm (48 in.) in length; and
 - 180 mm to 280 mm (7 in. to 11 in.) above the rim.
 - ii) One vertically at the foot end of the bathtub adjacent to the clear floor space - **Figure 5.2.8(a)**:
 - at least 1220 mm (48 in.) minimum in length; and
 - 180 mm to 280 mm (7 in. to 11 in.) above the rim at the lower end.
 - iii) Vertical grab bars should not interfere with the shower curtain.
 - iv) Grab bars on pre-fabricated units are only acceptable if they comply with section 5.2.10 *Grab Bars*.

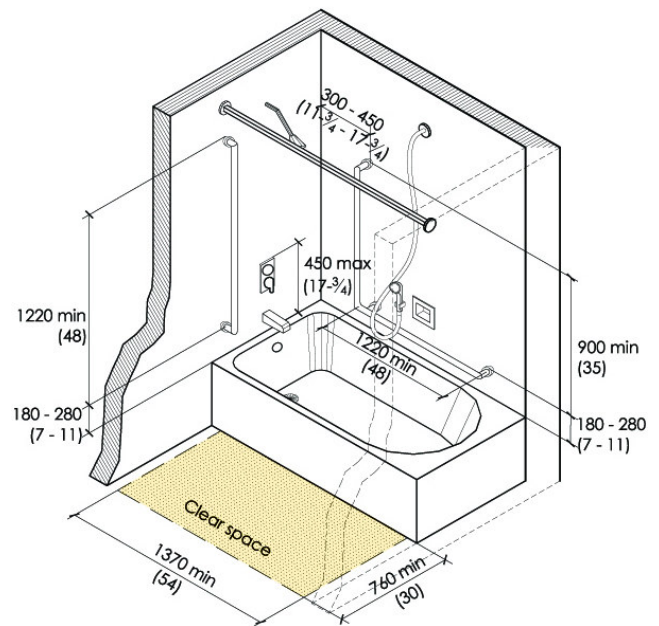

Figure 5.2.8(a)
Bathtub



- d) Faucets and other controls shall:
 - i) comply with section 5.2.4 *Lavatories*;
 - ii) be located at the foot of the bathtub between the centre line of the bathtub and the clear floor space (closer to the open side of the tub is preferred); and
 - iii) be not more than 450 mm (17-3/4 in.) above the rim - **Figures 5.2.8(a)** and **5.2.8(a)**.
- e) Enclosures: sliding doors shall not be provided on bathtubs.
- f) Slip resistant bases shall be provided.
- 2) Where it is deemed infeasible to have all bathtubs comply with this section, at least 10% but never less than one in each bathing area shall comply with this section.

Related Sections

- 5.1.1 Space and Reach Requirements
- 5.2.7 Washroom Accessories
- 5.2.10 Grab Bars
- 5.4.1 Controls and Operating Mechanism
- 6.4 Texture and Colour



Barriers and Obstacles

The accessibility of shower stalls requires that consideration be given to:

- safety supports such as grab bars and slip-resistant floors;
- assistive equipment such as benches and hand held showerheads allowing flexibility of use;
- colour contrasting of controls and stalls to assist persons with visual impairments;
- elimination of hazards and obstacles such as curbs or shower doors with thresholds; and
- manoeuvrability from chair to shower where chairs cannot get wet or space provided where a chair can be used in the shower.

There are 2 types of shower stalls;

- **Roll-in shower stalls:**
 - can accommodate the use of a wheeled shower chair; and
 - can be flexible if provided with a fold away seat or requirements for a portable seat.
- **Shower stalls with curbs:**
 - may be used where space is limited; and
 - are more suitable to wood frame construction.

Flexible roll-in stalls are preferred but are not always possible due to space limitations and building technology.

Design Requirements

Where shower stalls are provided they shall comply with this section:

- 1) Shower stalls shall be on an accessible route complying with section 5.1.4 *Accessible Routes, Paths and Corridors*.
- 2) Where it is deemed infeasible to have all shower stalls comply with this section, at least 10%, but never less than one, in each bathing area shall comply with this section.
- 3) The temperature of the water supplied to the shower stall shall:
 - a) not exceed 55°C; and
 - b) be controlled:
 - i) thermostatically; or
 - ii) by a pressure equalizing valve.



- 4) A **showerhead** - **Figure 5.2.9(a)** - shall:
 - a) be of the handheld type;
 - b) be provided with a hose at least 1525 mm (60 in.) long;
 - c) allow use in a fixed position;
 - d) be mounted to be adjustable but at a maximum height of 1200 mm (47 in.) from the floor; and
 - e) where mounted on a vertical bar, not have the location of the bar obstruct the use of the grab bars.
- 5) **Enclosures:**
 - a) Doors or curtains for shower stalls shall not obstruct the controls or the transfer space.
- 6) **Shower stall floors** shall:
 - a) be slip-resistant even when wet; and
 - b) slope minimally to provide positive drainage.
- 7) **Shower seat:**
 - a) Style/Type:
 - i) a wall-mounted, folding seat that is not spring loaded; or
 - ii) requirements for a portable seat; or
 - iii) a permanent seat.
 - b) Locate where a seated person can operate controls.
 - c) Size: at least 410 mm (16 in.) deep, and where possible, extending the full depth of the stall, but not less than 710 mm (28 in.) long, (less a space allowed for the shower curtain);
 - d) Height: 430 mm to 480 mm (17 in. to 19 in.) from the floor - **Figure 5.2.9(a)**;
 - e) Provide a smooth non-slip surface without rough edges;
 - f) Colour: a contrasting colour to improve its visibility;
 - g) Design to carry a minimum load of 1.33 kN (300 lbs) - **Figure 5.2.9(b)**.
- 8) Drain should be located beneath the seat or off to one side.
- 9) Where **roll-in shower stalls** are provided they shall comply with parameters below - **Figure 5.2.9(a)**:
 - a) **Shower Area:**
Have an interior clear area of at least 920 mm x 1525 mm (36 in. x 60 in.).
Where possible increase the 920 mm (36 in.) dimension.

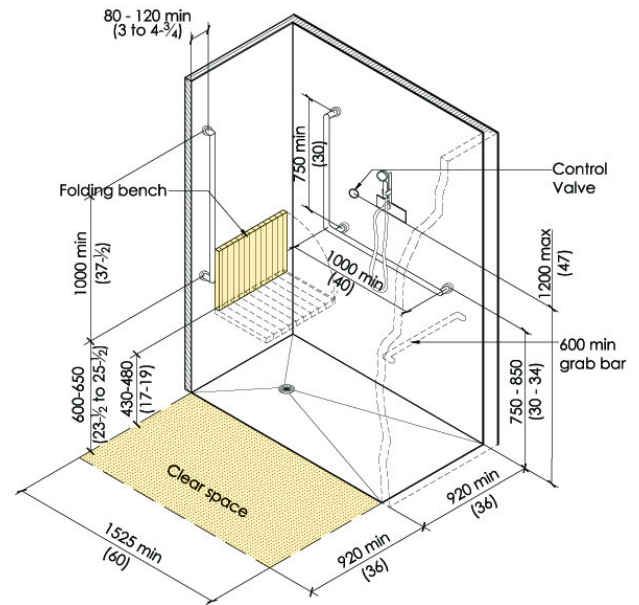

Figure 5.2.9(a)
Roll-in Shower Stall

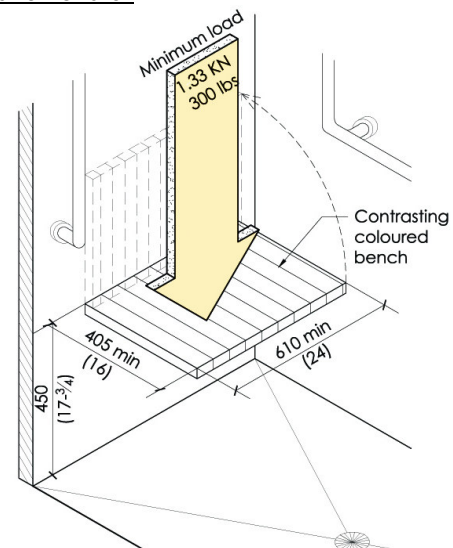

Figure 5.2.9(b)
Maximum Load Capacity for Fold Down Bench



b) **Access Area:**

A clear floor area in front of the shower entrance shall be at least 920 mm x 1525 mm (36 in. x 60 in.), with the 1525 mm (60 in.) dimension parallel to the shower entrance.

c) **Grab bars - Figures 5.2.9(a), 5.2.9(c) and 5.2.9(d):**

In roll-in showers, four grab bars that comply with section 5.2.10 Grab Bars shall be mounted as follows:

One horizontally on a side wall:

- i) at least 600 mm (23-3/4 in.) in length; and
- ii) 750 to 850 mm (29-1/2 to 33-1/2 in.) from the floor;

One vertically on the opposite side wall:

- i) at least 1000 mm (39-1/2 in.) in length;
- ii) with the lower end 600 mm to 650 mm (23-3/4 in. to 25-1/2 in.) from the floor; and
- iii) at 50 mm to 80 mm (2 to 3-1/4 in.) from the outside edge of the shower stall;

One horizontally on the back wall:

- i) at least 1000 mm (39-1/2 in.) in length; and
- ii) 750 mm to 850 mm (29-1/2 – 33-1/2 in.) from the floor; and

One vertically on the back wall:

- i) at least 750 mm (29-1/2 in.) in length;
- ii) with the lower edge 50 mm to 60 mm (2 in. to 2-1/2 in.) above the horizontal grab bar in item (c) or use continuous “L” shape grab bar; and
- iii) located 400 mm to 500 mm (15-3/4 in. to 19-3/4 in.) from the side wall on which the other vertical grab bar is mounted.

d) **Seat:**

In a roll-in shower a seat is optional. Where one is provided refer to item 7 above.

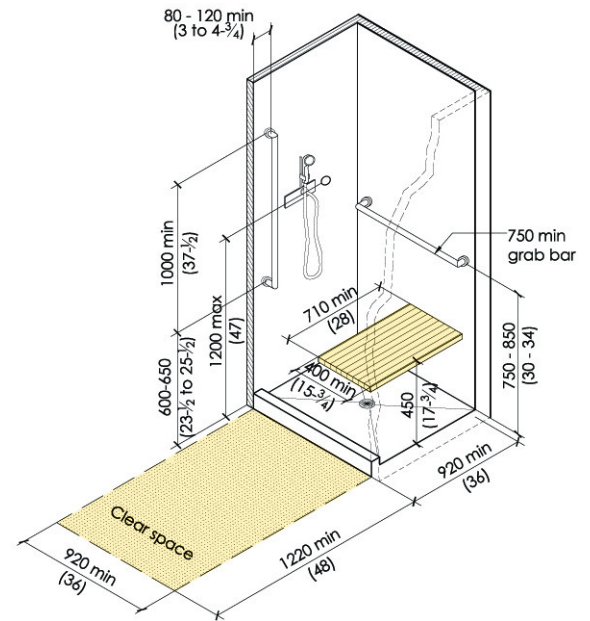

Figure 5.2.9(c)
Shower Stall

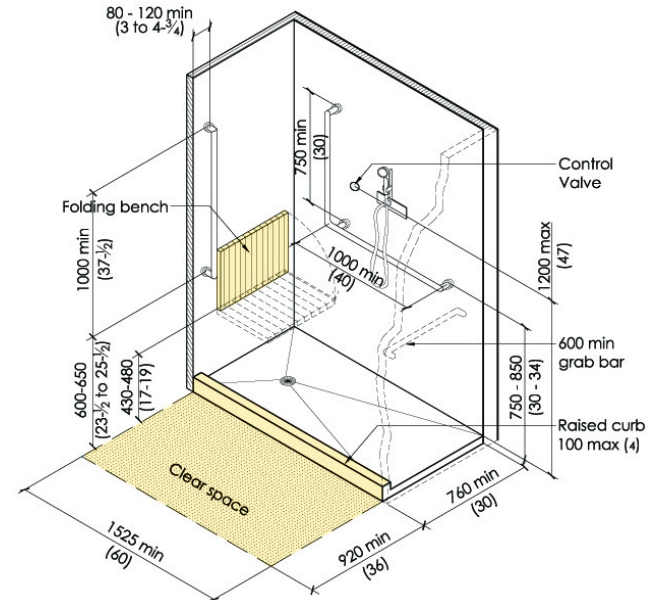

Figure 5.2.9(d)
Shower Stall



- e) **Thresholds:**
A threshold at the entrance to a roll-in shower shall:
- i) not exceed 13 mm (1/2 in.) in height; and
 - ii) if between 7 mm and 13 mm (1/4 in. and 1/2 in.) in height, be bevelled at a slope no steeper than the ratio of 1:2 (50%).
- f) **Controls:**
Faucets and controls for roll-in shower stalls shall:
- i) comply with section 5.4.1 *Controls and Operating Mechanisms*;
 - ii) be mounted in the centre on the back wall above the grab bar; and
 - iii) be no more than 1220 mm (48 in.) from the floor.
- 10) Where **shower stalls with curbs** are provided, they shall comply with the parameters below - **Figure 5.2.9(c)** and **5.2.9(d)**.
- a) **Shower Area:**
Shower stalls with a curb shall have an interior clear space of at least 920 mm x 920 mm (36 in. x 36 in.) - **Figure 5.2.9(c)**.
- b) **Access Area:**
The clear floor area in front of the shower entrance shall be at least 920 mm x 1220 mm (36 in. x 48 in.), with the 1220 mm (48 in.) dimension parallel to the shower entrance, starting from the stall wall opposite the seat.
- c) **Seat:**
In shower stalls with a curb, a seat shall be provided (refer to point 7 above).
- d) **Grab Bars:**
Two grab bars that comply with section 5.2.10 *Grab Bars* shall be mounted as follows:
- One horizontally, on the back wall, that is
- i) 750 mm to 850 mm (29-1/2 in. to 33-1/2 in.) from the shower floor; and
 - ii) at least 750 mm (29-1/2 in.) in length; and
- One vertically, on the same wall as the controls, that is:
- i) 80 mm to 120 mm (3 in. to 5 in.) from the outside edge;
 - ii) with the lower end 610 mm to 650 mm (24 in. to 25-1/2 in.) from the floor; and
 - iii) at least 1000 mm (39 in.) in length.



- e) **Faucets and controls** shall:
 - i) comply with 5.4.1 *Controls and Operating Mechanisms*;
 - ii) be mounted within reach of the seat;
 - iii) be mounted not more than 1200 mm (47 in.) from the floor; and
 - iv) be accessible from outside the stall.
- f) **Shower Curbs** shall:
 - i) not be higher than 100 mm (4 in.);
 - ii) have a width less than 100 mm (4 in.); and
 - iii) be colour contrasted to improve visibility.

Related Sections

- 5.1.1 Space and Reach Requirements
- 5.2.7 Washroom Accessories
- 5.2.10 Grab Bars
- 5.4.1 Controls and Operating Mechanisms
- 6.4 Texture and Colour





Barriers and Obstacles

Grab bars are essential for many individuals who require assistance in activities such as getting up, sitting down or standing for extended periods of time.

Design Requirements

- 1) Grab bars shall - **Figure 5.2.10(a)**:
 - a) resist a horizontal or vertical load of at least 1.3 kN (300 lb.) when installed;
 - b) be a minimum of 30 mm (1-3/16 in.) and a maximum of 40 mm (1-9/16 in.) in diameter;
 - c) have a clearance of 30 mm to 40 mm (1-3/16 in. to 1-9/16 in.) from the wall;
 - d) be free of any sharp or abrasive elements;
 - e) be of contrasting colour with the surrounding environment;
 - f) be slip resistant; and
 - g) not rotate within fittings.
- 2) Surrounding surfaces shall be free of sharp elements.
- 3) Horizontal grab bars should be on three sides of a shower or bathtub.

Related Sections

- 5.1.1 Space and Reach Requirements
- 5.2.3 Toilets
- 5.2.5 Urinals
- 5.2.6 Individual Washrooms
- 5.2.8 Bathtubs
- 5.2.9 Shower Stalls
- 6.4 Texture and Colour

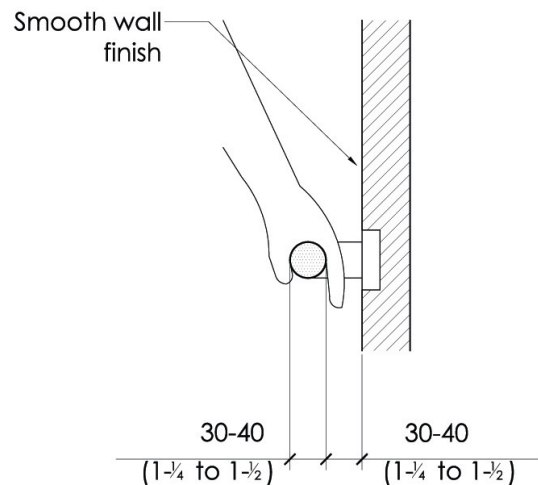

Figure 5.2.10(a)
Handrail





Amenities are usually provided as pre-designed units, e.g. pay phones, vending machines, drinking fountains, etc. Consideration should be given to issues such as mounting heights and reach requirements for a divergent population, so as to be inclusive.

This section deals with the design, provision of requirements for universally accessible comforts that improve the quality of life of a population e.g. park benches, water fountains etc.

5.3.

- 1 Street Furniture
- 2 Public Telephones
- 3 Waiting and Queuing Areas
- 4 Information, Reception and Service
Counters
- 5 Offices and Work Areas
- 6 Tables, Counters and Work Surfaces
- 7 Drinking Fountains
- 8 Lockers
- 9 Ticketing Machines



Barriers and Obstacles

Street furniture, which provides a resting place for persons who have difficulty walking long distances, should be located off of the path of travel.

Street furniture includes but is not limited to:

- benches;
- light standards;
- mail boxes;
- planters;
- signs;
- waste receptacles; and
- vending machines.

Design Requirements

- 1) **Street furniture** wherever possible shall:
 - a) not reduce the required width of an accessible route as specified in section 5.1.4 *Accessible Routes, Paths and Corridors*;
 - b) be indicated by a cane-detectable strip, in compliance with section 5.1.3 *Protruding Objects*;
 - c) be located to one side of the clear way;
 - d) be securely mounted on an amenity strip with a minimum width of 610 mm (24 in.), located adjoining walkways, paths sidewalks and other accessible routes; and
 - e) be of contrasting colour to the surrounding environment.
- 2) **Waste receptacles** shall:
 - a) be of a sufficient size to contain the anticipated waste;
 - b) be mounted on level, firm pads when located in open areas, such as wilderness areas, parks, beaches or picnic areas;
 - c) be identified using suitable lettering in compliance with section 6.7 *Signage and Wayfinding*;
 - d) have lids or openings that are mounted no higher than 1065 mm (42 in.) above the adjacent floor or ground surface, in compliance with section 5.4.1 *Controls and Operating Mechanisms*; and
 - e) be provided near each accessible public entrance.
 - f) include shaped openings to differentiate between waste, paper, and cans a glass where recycling receptacles are provided.



- 3) **Benches** wherever possible shall:
- a) be adjacent to an accessible route in compliance with section 5.1.4 *Accessible Routes, Paths and Corridors*;
 - b) be located on a level and firm surface;
 - c) be provided with an adjacent space 1015 mm x 1220 mm (40 in. x 48 in.) for at least one person using a scooter or a wheelchair; and
 - d) have a seat height of 450 mm to 500 mm (17-3/4 in. to 19-3/4 in.) from the ground.
 - e) include suitable back and arm supports to allow for easy transfers for persons with physical limitations.

Related Sections

- 5.1.1 Space and Reach Requirements
- 5.1.2 Ground and Floor Surfaces
- 5.1.3 Protruding Objects
- 5.1.4 Accessible Routes, Paths and Corridors
- 5.1.5 Exterior Pedestrian Routes
- 6.3 Materials and Finishes
- 6.4 Texture and Colour
- 6.5 Urban Braille
- 6.8 Detectable Warning Surfaces



Barriers and Obstacles

When placing a public telephone, the following factors should be taken into consideration:

- limited reach of children and individuals in wheelchairs, or very tall persons;
- longer phone cords for those who can not get close to the telephone due to mobility devices;
- volume controls; and
- shelves for TDD (Telecommunications Device for the Deaf).

Design Requirements

- 1) Where public telephones are provided in an exterior area, a minimum of one telephone should be designed to be accessible from a wheelchair or other mobility aids.
- 2) Controls or coin slots should be mounted at a maximum of 1200 mm (47 in.) from the ground or floor - **Figure 5.3.2(a)**.
- 3) Public telephones that are in an enclosure or are recessed should have a knee space of at least 760 mm (30 in.) wide and 685 mm (27 in.) clear height under the telephone or shelf - **Figure 5.3.2(a)**.
- 4) Telephones should be mounted clear of door swings or other obstacles, and to one side of the path of travel with enough open space for access by persons using wheelchairs or other mobility aids.
- 5) Lighting at public telephones should be at a level of at least 200 lux (18.6 ft-candles).
- 6) Public telephones which are accessible should be clearly identified by the "International Symbol of Accessibility" (See Section 6.7 *Signage and Wayfinding*).
- 7) Where multiple telephones are provided, one should be available that may accommodate persons who are deaf, deafened, or hard of hearing. These devices include but are not limited to: an acoustic coupler, volume control etc. Telephones equipped with these devices must be clearly identified with the "international symbol" for persons who are deaf, deafened or hard of hearing.

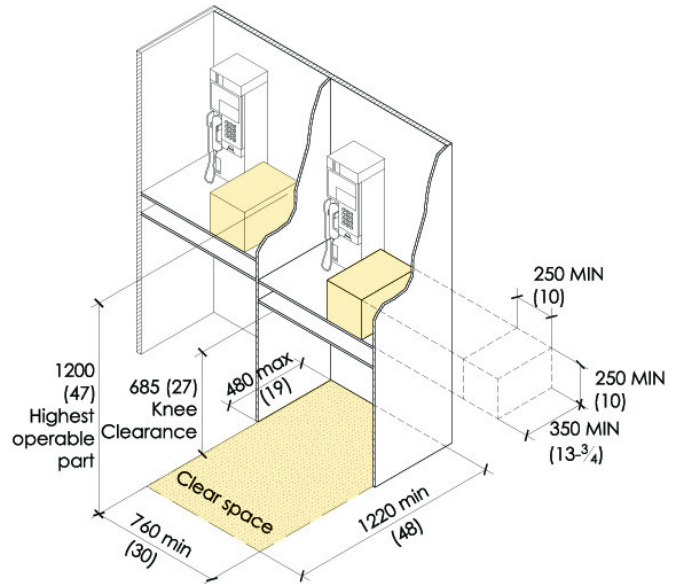

Figure 5.3.2(a)
Public Telephones



- 8) Where more than one public telephone is available side by side, a TTY device (Text Telephone) should be provided for persons who are deaf, deafened or hard of hearing - **Figure 5.3.2(a)**.
- 9) Where possible, public telephones should be located in a quiet area.
- 10) A Decision Node Symbol should mark the location of public telephones where Urban Braille is used. Refer to *Section 6.5 Urban Braille*.

Related Sections

- 5.1.1 Space and Reach Requirements
- 5.1.3 Protruding Objects
- 5.1.4 Accessible Routes, Paths and Corridors
- 5.1.5 Exterior Pedestrian Routes
- 5.3.1 Street Furniture
- 5.4.1 Controls and Operating Mechanisms
- 6.2 Lighting
- 6.4 Texture and Colour
- 6.5 Urban Braille
- 6.7 Signage and Wayfinding



Barriers and Obstacles

Waiting and queuing areas should provide enough space for individuals using mobility devices such as scooters and wheelchairs to proceed through the line safely. Providing handrails and benches will allow support for individuals who require visual assistance or have difficulty standing for long periods of time.

Design Requirements

- 1) Waiting and queuing areas, wherever possible, shall:
 - a) be a minimum of 1060 mm (41-3/4 in.) in width;
 - b) be laid out in a logical, parallel manner;
 - c) have barriers that are firmly mounted to the floor or ground;
 - d) be clearly indicated by some means e.g. a colour change or a physical barrier; and
 - e) be located in a well-lit area.
- 2) Permanent waiting or queuing areas shall comply to the colour and texture guidelines laid out in section 6.4 *Texture and Colour* to aid individuals with visual impairments.
- 3) Floor slots or pockets used for temporary or occasional support of barriers shall be flush with the floor finish and have a cover to eliminate a tripping hazard.

Related Sections

- 5.1.1 Space and Reach Requirements
- 5.1.2 Ground and Floor Surfaces
- 5.1.4 Accessible Routes, Paths and Corridors
- 5.3.2 Public Telephones
- 5.2.1 Glare and Light Sources
- 6.2 Lighting
- 6.3 Materials and Finishes
- 6.4 Texture and Colours
- 6.6 Information Systems
- 6.7 Signage and wayfinding
- 6.8 Detectable Warning Surfaces
- 7.1 Acoustics
- 7.2 Public Address Systems
- 7.4 Assistive Listening Systems





Barriers and Obstacles

Information, reception and service counters and writing surfaces should be at a height to serve children, individuals who are short in stature and individuals who are in wheelchairs. Colour and texture may also aid individuals with visual impairments locate the counters.

Design Requirements

- 1) Information, reception and service counters shall be located on an accessible route in compliance with section 5.1.4 *Accessible Routes, Paths and Conditions*.
- 2) At least one counter for information, reception or service shall be accessible by individuals in wheelchairs. This counter shall:
 - a) be at least 760 mm (30 in.) wide and between 710 mm and 865 mm (28 in. and 34 in.) above the finished floor or ground - **Figure 5.3.4(a)**;
 - b) have a knee space of at least 685 mm (27 in.) high by 480 mm (19 in.) deep; and
 - c) incorporate a clear floor space of not less than 760 mm x 1370 mm (30 in. x 54 in.).
- 3) If a forward approach is used to access the information, reception or service counter, there shall be a clear knee space of at least 760 mm (30 in.) wide, 480 mm (19 in.) deep and 685 mm (27 in.) high provided. It may overlap the clear floor space by a maximum of 480 mm (19 in.).
- 4) Speaking ports provided at accessible information, reception or service counters shall be no higher than 1060 mm (41-3/4 in.) above the finished floor or ground.
- 5) Signage locating information or service counters shall comply with section 6.7 *Signage and Wayfinding*.

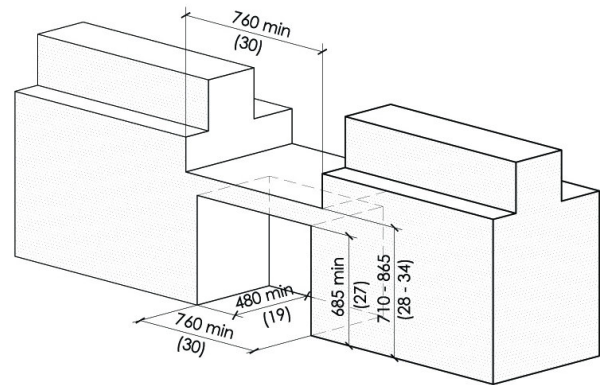

Figure 5.3.4(a)
Service Counter

Related Sections

- 5.1.1 Space and Reach Requirements
- 5.1.4 Accessible Routes, Paths and Corridors
- 6.1 Glare and Light Sources
- 6.2 Lighting
- 6.3 Materials and Finishes
- 6.6 Information Systems
- 6.7 Signage and Wayfinding
- 7.4 Assistive Listening Systems





Barriers and Obstacles

Offices and work areas that provide services to the public should be accessible to any individual regardless of their level of mobility. A quiet acoustical environment benefits all individuals who use a space, especially those with hearing impairments. Background noises such as mechanical equipment or music should be minimised.

Workstations and tables provided in offices, work areas and meeting rooms should have enough knee space to accommodate an individual in a wheelchair. Mobility devices such as scooters need to be considered for circulation areas.

Naturally coloured task lighting, such as halogen task lighting, will facilitate use of all individuals, especially those with vision impairments. Blinds that allow upward louvers may be considered where large expanses of glass produce glare.

Design Requirements

- 1) Offices and work areas provided for the use of clients, customers or the general public shall: (Refer also to *Section 5.3.6 Tables, Counters and Work Surfaces*)
 - a) be located on an accessible route complying with section 5.1.4 *Accessible Routes, Paths and Corridors*;
 - b) if a door is provided, the door shall comply with section 5.1.9 *Doors*;
 - c) have sufficient clear floor space to allow an individual in a wheelchair to make a 180 degree turn;
 - d) have a route so that an individual in a wheelchair may access the space without having to travel backwards to enter or leave the space;
 - e) have the primary activity elements connected by an accessible route in compliance with section 5.1.4 *Accessible Routes, Paths and Corridors*;
 - f) have knee clearance under work areas in compliance with section 5.1.6 *Vehicular Access*;
 - g) comply to section 5.1.4 *Accessible Routes, Paths and Corridors* in regards to shelving, storage or display units where accessible by the general public, customers or clients;
 - h) where photocopiers, fax machines etc. are provided for the use of the general public, clients or customers, a clear floor space in compliance with section 5.1.4 *Accessible Routes, Paths and Corridors* shall be provided; and





- i) be supplied with an assistive listening system that complies with section 7.4 *Assistive Listening Systems*, where an assistive listening system is required. Refer to section 8.1 *Meeting Rooms, Assembly Areas and Theatres*
- 2) Rooms intended for public use should have a sign, which complies with section 6.7 *Signage and Wayfinding*, indicating the intended use of the room.

Related Sections

- 5.1.1 Space and Reach Requirements
- 5.1.2 Ground and Floor Surfaces
- 5.1.4 Accessible Routes, Paths and Corridors
- 5.3.6 Tables, Counters and Work Surfaces
- 5.4.1 Controls and Operating Mechanisms
- 6.1 Glare and Light Sources
- 6.2 Lighting
- 6.3 Materials and Finishes
- 6.4 Texture and Colour
- 6.7 Signage and Wayfinding
- 6.9 Windows, Glazed Screens and Sidelights
- 7.1 Acoustics
- 7.4 Assistive Listening Systems
- 7.5 Visual Alarms
- 8.1 Meeting Rooms, Assembly Areas and Theatres



Barriers and Obstacles

Tables, counters and work surfaces are utilised by many different users and should accommodate each of them. Work surfaces need to be high enough to give an individual in a wheelchair enough knee space to easily pull in to, while the placement of the furniture should allow individuals with wheelchairs or scooters space to turn around.

Design Requirements

- 1) Fixed or built-in tables, counters and work surfaces that are accessible in a public or common area, at least 10% but not less than 1 shall comply with this section.
- 2) Accessible tables, counters and work surfaces shall be located on an accessible route complying with section 5.1.4 *Accessible Routes, Paths and Corridors*.
- 3) Seating for wheelchair shall have a clear floor space of not less than 760 mm x 1370 mm (30 in. x 54 in.) at accessible tables, counters and work stations - **Figures 5.3.6(a)** and **5.3.6(b)**.
- 4) Access from a forward approach should have a clear space of at least 760 mm (30 in.) wide, 480 mm (19 in.) deep and 685 mm (27 in.) high shall be provided. It may overlap the clear floor space by a maximum of 480 mm (19 in.) - **Figures 5.3.6(a)**, and **5.3.6(b)**.
- 5) Access from a parallel approach should have a clear space of at least 1370 mm (54 in.) wide, 760 mm (30 in.) deep shall be provided - **Figure 5.3.6(c)**.
- 6) Accessible tables, counters and work surfaces should be located at a minimum of 710 mm (28 in.) to a maximum of 865 mm (34 in.) above the finished floor - **Figure 5.3.6(a)**.
- 7) Table legs should be spaced far enough apart as to allow a wheelchair or scooter to manoeuvre and position under the table.
- 8) Any obstruction under a table, counter or work surface, should be clearly visible upon approach.

Related Sections

- 5.1.1 Space and Reach Requirements
- 5.1.4 Accessible Routes, Paths and Corridors

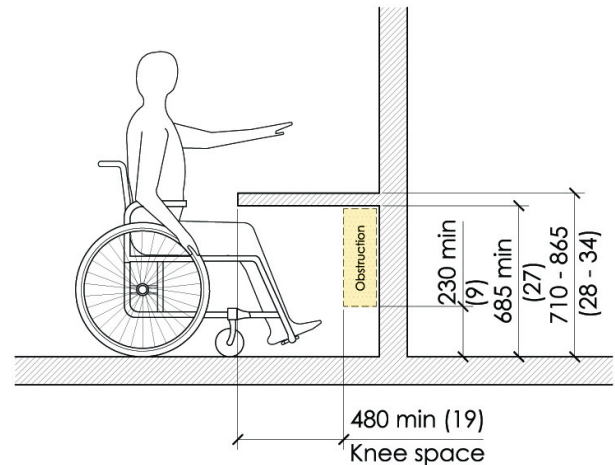

Figure 5.3.6(a)
Clearances

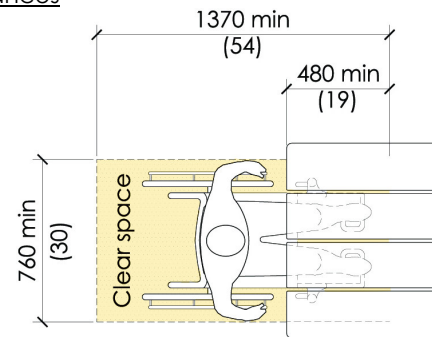

Figure 5.3.6(b)
Frontal Approach

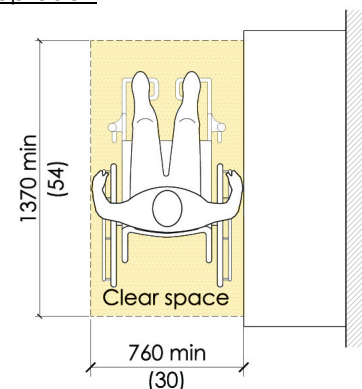

Figure 5.3.6(c)
Parallel Approach





Barriers and Obstacles

When planning a drinking fountain, factors such as height, strength and placement should be taken into consideration. Individuals who are short in stature or in a wheelchair need a lower unit while individuals who have difficulties bending require a taller unit. An individual's hand strength or dexterity should be taken into account when choosing an operating system. Fountains should be out of the path of travel or recessed to ensure safe travel for an individual with a visual impairment.

Design Requirements

- 1) Where drinking fountains are provided, at least one shall be accessible.
- 2) Where there is only one drinking fountain on a floor, that fountain shall be accessible and an adjacent paper cup dispenser should be provided (for persons who have difficulty bending).
- 3) Where possible, preference should be given to parallel approach drinking fountains.
- 4) Accessible drinking fountains shall:
 - a) be located on an accessible route in compliance with section 5.1.4 *Accessible Routes, Paths and Corridors*;
 - b) have a spout located near the front of the unit between 760 mm and 915 mm (30 in. and 36 in.) above the floor or ground surface;
 - c) have a spout that directs the water flow parallel or near parallel to the front of the drinking fountain, and control the flow of water to allow for slow drinking ;
 - d) have a spout that provides a water flow at least 100 mm (4 in.) high; and
 - e) have controls that are either automatic, or may be operated using only one hand with a force of not greater than 22N (4.9 lb.).
- 5) Cantilevered drinking fountains shall - **Figures 5.3.7(a) and 5.3.7(b)**:
 - a) have a clear floor space of at least 760 mm by 1370 mm (54 in. by 30 in.);
 - b) have a knee space between the bottom of the apron and the floor or ground of at least 760 mm (30 in.) wide, 200 mm (8 in.) deep and 685 mm (27 in.) high - **Figure 5.3.7(c)**;

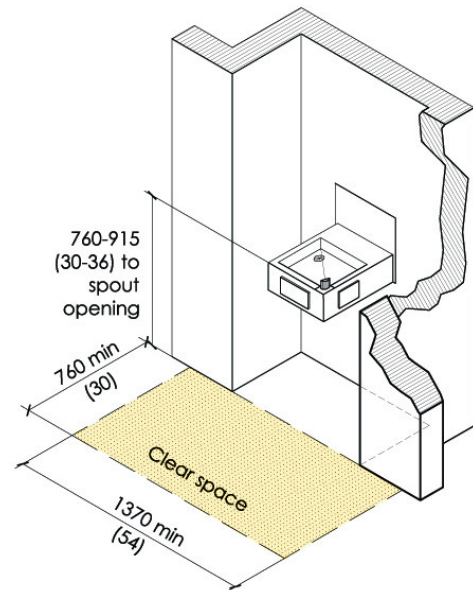

Figure 5.3.7(a)
Parallel Approach

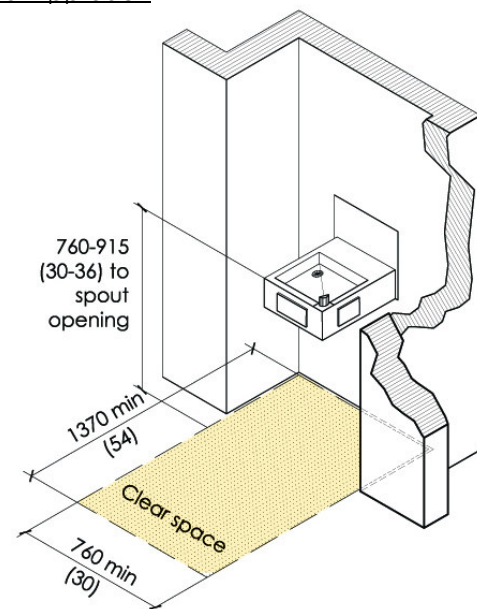

Figure 5.3.7(b)
Frontal Approach



- c) have a toe space not less than 760 mm (30 in.) wide, 230 mm (9 in.) deep, and 230 mm (9 in.) high; and
 - d) be recessed or otherwise located out of the circulation path.
- 6) Fountains not having a knee space shall have a clear floor space of at least 1370 mm (54 in.) wide by 760 mm (30 in.) deep in front of the unit.
- 7) Where possible, there should be no protrusion above the drinking fountain.

Related Sections

- 5.1.1 Space and Reach Requirements
- 5.1.2 Ground and Floor Surfaces
- 5.1.3 Protruding Objects
- 5.1.4 Accessible Routes, Paths and Corridors
- 6.3 Materials and Finishes
- 6.4 Texture and Colour

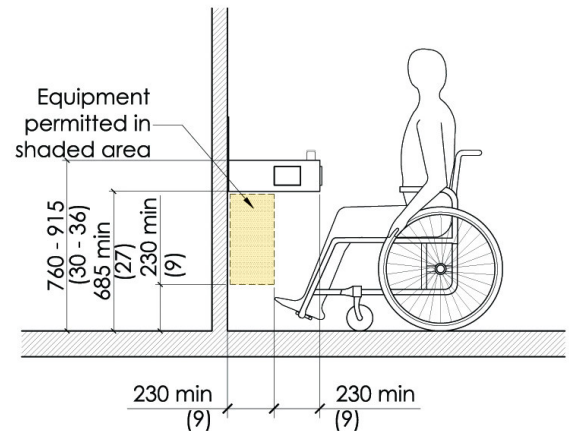

Figure 5.3.7(c)
Clearances



Barriers and Obstacles

Public buildings such as schools, recreational facilities and transit facilities that provide public storage lockers should ensure that at least some of the units are accessible. The lower lockers serve the reach restrictions of children or individuals using wheelchairs

Design Requirements

- 1) Lockers that are to be accessible must be on a route that complies with section 5.1.4 *Accessible Routes, Paths and Corridors*;
- 2) Shelves in accessible lockers shall be no lower than 460 mm (18 in.) but no higher than 1220 mm (48 in.) above the finished floor.
- 3) Locks should be located approximately 915 mm (36 in.) from the floor, but shall be no higher than 1056 mm (41-1/2 in.).
- 4) Aisle spaces in front of lockers shall comply with section 5.1.4 *Accessible Routes, Paths and Corridors* to permit forward and lateral approach by wheelchair users.

Related Sections

- 5.1.1 Space and Reach Requirements
- 5.1.4 Accessible Routes, Paths and Corridors
- 5.4.1 Controls and Operating Mechanisms
- 6.2 Lighting
- 6.4 Texture and Colour
- 6.7 Signage and Wayfinding





Barriers and Obstacles

Ticketing machines, access technologies and automated service centres (e.g. bank machines, license renewal booths, carded access gates etc.) are becoming more commonplace. Consideration should be given to how these technologies are accessed by persons with disabilities.

- Access
- Lighting
- Signage

Design Requirements

- 1) Both interior and exterior ticketing machines shall:
 - a) be on an accessible route (excepting machines intended for use by persons in a vehicle);
 - b) not have operable or dispensing parts higher than 1200 mm (47 in.) or lower than 915 mm (36 in.) above finished floor; and
 - c) be operable by persons with limited dexterity.
- 2) Control buttons or card access locations shall:
 - a) be on an accessible route (excepting machines intended for use by persons in a vehicle);
 - b) not be higher than 1200 mm (47 in.) or lower than 915 mm (36 in.) above finished floor;
 - c) be easily identifiable, by clear signage and contrasting colours; and
 - d) be operable by persons with limited dexterity.
- 3) Screen sizes, text appearance and size should be considered when purchasing such technologies.

Related Sections

- 5.1.1 Space and Reach Requirements
- 5.1.4 Accessible Routes, Paths and Corridors
- 5.3.1 Controls and Operating Mechanisms
- 6.2 Lighting
- 6.4 Texture and Colour
- 6.7 Signage and Wayfinding





When designing or planning for items that require physical interaction for use (e.g., a door knob/lever), it is important to consider persons with limited dexterity.

Children, seniors, persons with cognitive disabilities, etc., are all affected by such designs, which ultimately affect issues such as personal rights and safety.

This section deals with the design, and provision of requirements for universal design with regard to the operation, function and use of amenities provided, notwithstanding any physical limitations.

5.4.

- 1 Controls and Operating Mechanisms
- 2 Emergency Exits, Fire Evacuation and Areas of Rescue Assistance



Barriers and Obstacles

Controls and operating mechanisms that require a high degree of strength to operate may be difficult for children, individuals with arthritis and people wearing gloves to use. If two hands are needed to operate a mechanism, individuals using canes, crutches or other mobility devices have difficulty operating them.

Controls must be low enough to allow an individual in a wheelchair to reach, and space to position the wheelchair in front of the controls.

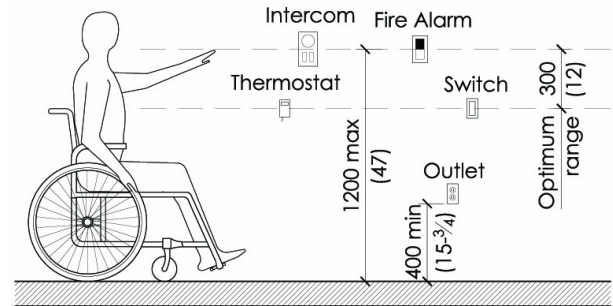

Figure 5.4.1(a)
Reach Range for Accessible Controls

Design Requirements

- 1) Around operating mechanisms, a 760 mm by 1370 mm (30 in. by 54 in.) clear space shall be provided.
- 2) Operable portions such as dispensers and receptacles shall be located between 400 mm and 1200 mm (15-3/4 in. and 47 in.) from the floor - **Figure 5.4.1(a)**.
- 3) Faucets and other controls shall be hand-operated or electronically controlled.
- 4) Hand-operated controls shall be operable:
 - a) with one hand;
 - b) without twisting of the wrist, tight grip or pinching; and
 - c) with a force of less than 22kN (5 lbs.).
- 5) Operating mechanisms and controls shall be:
 - a) illuminated sufficiently to a minimum level of 100 lux (10 ft-candles), so as not to create shadows;
 - b) in contrasting colour with the surrounding environment; and
 - c) where print or numerals are required on controls or opening mechanisms, such figures shall be large print.



Related Sections

- 5.1.1 Space and Reach Requirements
- 5.1.3 Protruding Objects
- 5.1.4 Accessible Routes, Paths and Corridors
- 5.1.9 Doors
- 5.1.10 Gates, Turnstiles and Openings
- 5.1.16 Elevators
- 5.1.17 Platform Lifts
- 5.2.2 Toilet Stalls
- 5.2.3 Toilets
- 5.2.4 Lavatories
- 5.2.5 Urinals
- 5.2.6 Individual Washrooms
- 5.2.7 Washroom Accessories
- 5.2.8 Bathtubs
- 5.2.9 Shower Stalls
- 5.3.1 Street Furniture
- 5.3.2 Public Telephones
- 5.3.5 Offices, Work Areas and Meeting Rooms
- 5.3.7 Drinking Fountains
- 6.4 Texture and Colour
- 6.6 Information Systems
- 6.9 Windows, Glazed Screens and Sidelights



Barriers and Obstacles

Emergency exit doors must comply with section 5.1.4 *Accessible Routes, Paths and Corridors* in order to be accessible for all individuals. Doors and routes must be marked with appropriate signage so that individuals that may have difficulty with literacy such as children or individuals speaking a different language may understand them. Audio or talking signs may help individuals with visual disabilities. Areas of rescue assistance shall be provided in the event of a fire when elevators cannot be used.

Design Requirements

- 1) Facilities that are required to be accessible shall be provided with the amount of exits as required in the Ontario Building Code.
- 2) Every occupiable level in non-residential occupancies above or below the first storey (as defined by the Ontario Building Code) that is accessible, shall:
 - a) be served by an elevator that has protection features as specified in section 3.3.1.7 of the Ontario Building Code; and
 - b) be divided into at least two zones by fire separations, as specified in section 3.3.1.7 of the Ontario Building Code.
- 3) Where an appropriate balcony is provided above or below the first storey in a residential occupancy, the requirements for two fire zones or a protected elevator may be waived.
- 4) Warning systems, where provided, shall include audio and visual alarms. Visual alarms shall comply with section 7.5 *Visual Alarms*.
- 5) Accessible means of egress shall comply with section 5.1.4 *Accessible Routes, Paths and Corridors*.
- 6) Signage identifying accessible means of egress shall comply with section 6.7 *Signage and Wayfinding*.



- 7) Areas of rescue assistance:
- shall be provided where there is an inaccessible exit;
 - may be horizontal exiting, provided the exit meets the requirements of the Ontario Building Code;
 - are not required in a facility supplied with a supervised automatic sprinkler system.
 - shall comply with section 5.1.4 *Accessible Routes, Paths and Corridors*;
 - will have a minimum clear space of 850 mm by 1370 mm (33-1/2 in. by 54 in.) per non-ambulatory occupant, with a minimum of two spaces per floor - **Figure 5.4.2(a)**;
 - shall have a fire separation possessing a fire resistance rating at least equal to that of an exit separating the area of rescue assistance from the floor area;
 - shall be served by an exit or firefighters elevator;
 - shall be designated as an area of rescue assistance;
 - shall have smoke protection if facility is more than three storeys; and
 - shall have identifying signage in compliance with section 6.7 *Signage and Wayfinding*.

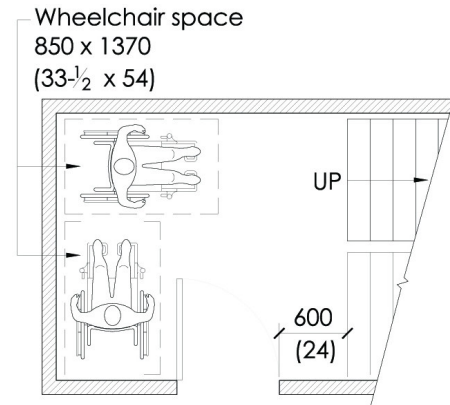

Figure 5.4.2(a)
Area of Rescue Assistance

Related Sections

- 5.1.1 Space and Reach Requirements
- 5.1.2 Ground and Floor Surfaces
- 5.1.3 Protruding Objects
- 5.1.4 Accessible Routes, Paths and Corridors
- 5.1.9 Doors
- 5.4.1 Controls and Operating Mechanisms
- 6.3 Materials and Finishes
- 6.4 Texture and Colour
- 6.7 Signage and Wayfinding
- 6.8 Detectable Warning Surfaces
- 6.5 Visual Alarms



Access and use of spaces by persons with visual impairments can be very simple if careful consideration is given to issues during the design stage.

The use of colour and textural contrasting can be used in many ways to provide clues of pending events e.g., the approach to a change in level.

Considering the selection of materials to minimise glare, or prevent “hot spots” on surfaces, goes a long way to the comfort of persons with visual impairments.

This section deals with the design and provision of requirements for universal access, notwithstanding visual limitations.

6.0.

- 1 Glare and Light Sources
- 2 Lighting
- 3 Materials and Finishes
- 4 Texture and Colour
- 5 Urban Braille
- 6 Information Systems
- 7 Signage and Way finding
- 8 Detectable Warning Surfaces
- 9 Windows, Glazed Screens and Sidelights



Barriers and Obstacles

Glare can be distracting to all individuals. For this reason floors, walls and other work surfaces should have little to no reflective glare, as it is a major problem for individuals with reduced vision. This can be achieved in a variety of ways such as:

- strategically placing lighting sources;
- installing blinds on natural light sources, especially those which face west and south-west; and
- installing task lighting.

Design Requirements

- 1) Large expanses of flooring shall have a matte or honed finish to reduce reflective glare. High gloss materials may be incorporated as part of floor finish so long as it does not result in large reflective surfaces.
- 2) Horizontal surfaces shall be of matte or satin finish to reduce glare.
- 3) Vertical surfaces shall have matte or satin finishes. High gloss materials may be incorporated as part of wall finish so long as it does not result in large reflective surfaces.
- 4) Sun screenings, such as curtains or blinds, shall be provided where direct sunlight may negatively affect the level of lighting or reflective glare.
- 5) By incorporating lenses and diffusers, or using recessed light sources, light fixtures shall not create glare.
- 6) Surface-mounted fluorescent ceiling fixtures shall:
 - a) have darkened sides;
 - b) be positioned perpendicular to the dominant direction of travel; and
 - c) create an indirect light (e.g., valance type lighting).
- 7) Supplementary lighting shall be used to enhance special features and key orientation, provided they have only upward or downward components.



Related Sections

- 5.1.2 Ground and Floor Surfaces
- 5.1.4 Accessible Routes, Paths and Corridors
- 5.1.8 Entrances
- 5.1.12 Ramps
- 5.1.13 Stairs
- 5.1.15 Escalators
- 5.1.16 Elevators
- 5.1.17 Platform lifts
- 5.2.1 Toilet and Bathing Facilities
- 5.3.4 Information, Reception and Service
Counters
- 6.2 Lighting
- 6.9 Windows, Glazed Screens and Sidelights



Barriers and Obstacles

Lighting, either natural or artificial, should:

- be evenly distributed;
- provide a comfortable amount of illumination for the anticipated use of the space; and
- be present at frequently used entrances, access routes and outdoor facilities.

Design Requirements

- 1) Exterior lighting shall:
 - a) be in compliance with the Illuminating Engineering Society of North America (I.E.S.N.A.) in regards to providing safe access for persons with disabilities from sidewalks, bus stops and parking areas to nearby facilities;
 - b) have a minimum of 100 lux (10 ft-candles) consistently over pedestrian entrances;
 - c) have a minimum of 30 lux (3 ft-candles) consistently over pedestrian routes including walkways, paths, stairs etc.;
 - d) have a minimum of 30 lux (3 ft-candles) consistently over parking spots;
 - e) be bright enough to clearly illuminate treads, risers and nosings of frequently used steps and stairs;
 - f) be evenly distributed to minimise shadow;
 - g) provide a good colour spectrum;
 - h) highlight key signage and orientation landmarks;
 - i) be located at a height as to allow for normal snow removal; and
 - j) comply with section 7.3 *Waiting and Queuing Areas* where applicable.
- 2) Interior lighting shall:
 - a) have a minimal glare, whether direct or indirect, on surrounding surfaces;
 - b) produce as full a spectrum of light as possible;
 - c) be enhanced with incandescent lights where fluorescent or quartz lights are used to soften the light;
 - d) be distributed evenly to minimise pools of light and shadows;
 - e) be evenly dispersed at the leading edge of stairs, ramps and escalators;



- f) be consistent in elevator lobbies and elevator cabs to reduce a tripping hazard. This lighting shall be not less than 200 lux (20 ft-candles);
- g) where emergency lighting, be a minimum of 100 lux (10 ft-candles) over stairs and ramps in an exit or path of travel;
- h) be evenly distributed in meeting rooms and assembly areas;
- i) have the capability of adjustment (e.g., dimmers) in meeting rooms and assembly areas; and
- j) have the ability to be enhanced at speaker's areas even when other lighting is dimmed. This will permit ease of lip-reading or viewing of the hand actions of a nearby signer for individuals with hearing impairments.

Related Sections

- 5.1.4 Accessible Routes, Paths and Corridors
- 5.1.8 Entrances
- 5.1.12 Ramps
- 5.1.13 Stairs
- 5.1.15 Escalators
- 5.1.16 Elevators
- 5.1.17 Platform Lifts
- 5.2.1 Toilet and Bathing Facilities
- 5.3.2 Public Telephones
- 5.3.4 Information, Reception and Service Counters
- 5.3.5 Office, Work Areas and Meeting Rooms
- 5.3.7 Drinking Fountains
- 5.4.1 Controls and Operating Mechanisms
- 6.1 Glare and Light Sources
- 6.7 Signage and Wayfinding



Barriers and Obstacles

When choosing materials and finishes, consideration should be given to:

- ease of movement across flooring for individuals with mobility aids or vision impairments;
- slip resistance; and
- minimisation of glare.

Design Requirements

- 1) Paved surfaces suitable for walkways include but are not limited to:
 - a) macadam;
 - b) concrete;
 - c) compacted gravel screenings;
 - d) interlocking brick; and
 - e) patio stone.
- 2) Paved surfaces shall:
 - a) be sloped for easy drainage;
 - b) have a maximum joint space of 6 mm (1/4 in.); and
 - c) comply with section 6.1 *Glare and Light Sources*.
- 3) Gratings and grills shall:
 - a) be to one side of the walk; or
 - b) have bars perpendicular to the main direction of travel; and
 - c) have a maximum opening of 13 mm (1/2 in.).
- 4) Steps and stairs shall:
 - a) be non-slip; and
 - b) have highly contrasting nosings.
- 5) Ramps shall be firm with a non-slip finish.
- 6) Handrails and guardrails shall be:
 - a) continuous;
 - b) made of a smooth material; and
 - c) painted in a contrasting colour to the surrounding environment.



Related Sections

- 5.1.2 Ground and Floor Surfaces
- 5.1.4 Accessible Routes, Paths and Corridors
- 5.1.8 Entrances
- 5.1.12 Ramps
- 5.1.13 Stairs
- 5.1.15 Escalators
- 5.1.16 Elevators
- 5.1.17 Platform lifts
- 5.2.1 Toilet and Bathing Facilities
- 5.3.5 Office, Work Areas and Meeting Rooms
- 6.1 Glare and Light Sources



Barriers and Obstacles

Individuals with visual impairments may be dependent on colour or texture cues for navigation. These cues shall be simple and repetitive. Heavy or distinct materials should be used with caution as they may cause confusion.

Design Requirements

Texture:

- 2) Surfaces that are to be textured for warning shall be cane detectable and different from surrounding materials.
- 3) Suitable flooring textures include, but are not limited to:
 - a) exterior concrete with saw cuts not more than 50 mm (2 in.) apart. The saw cuts shall be at right angles to the path of travel;
 - b) raised domes, dots or squares;
 - c) deep grooved concrete, terrazzo or other stone materials. The grooves shall be at right angles to the path of travel; and
 - d) a carborundum material or other non-slip materials.
- 4) Supplementary textures may be used for minor paths of travel.
- 5) When defining a specific hazard, the same texture should be used throughout the building.

Colour:

- 1) Pronounced colour contrast shall be used to:
 - a) show boundaries of objects;
 - b) distinguish backgrounds; and
 - c) enhance spatial objects.
- 2) Warm colours should be used whenever possible, as they are easier for individuals with visual impairments to recognise.
- 3) Colour contrast should:
 - a) define or measure boundaries;
 - b) define the boundaries of a room by colour tone;
 - c) be used on baseboards in a monochromatic room to differentiate the boundaries;
 - d) be used consistently to identify specific objects (e.g., exit doors); and
 - e) be used on end or return walls to enhance the change of space.



- 4) Bright colours and high contrasting tones shall be used consistently throughout the building for wayfinding.
- 5) Signage shall:
 - a) be of glare free contrast;
 - b) reflect a minimum of 70% light contrast;
 - c) have contrasting colours such as white or yellow on black to enhance visibility; and
 - d) not use neutral colours such as light grey or pastel colours.

Related Sections

- 5.1.2 Ground and Floor Surfaces
- 5.1.4 Accessible Routes, Paths and Corridors
- 5.1.9 Doors
- 5.1.10 Gates, Turnstiles and Openings
- 5.1.12 Ramps
- 5.1.13 Stairs
- 5.1.14 Handrails
- 5.1.15 Escalators
- 5.1.16 Elevators
- 5.1.17 Platform Lifts
- 5.2.2 Toilet Stalls
- 5.2.3 Toilets
- 5.2.4 Lavatories
- 5.2.5 Urinals
- 5.2.6 Individual Washrooms
- 5.2.7 Washroom Accessories
- 5.2.8 Bathtubs
- 5.2.9 Shower Stalls
- 5.2.10 Grab Bars
- 5.3.1 Street Furniture
- 5.3.2 Public Telephones
- 5.3.3 Waiting and Queuing Areas
- 5.3.4 Information, Reception and Service
- 5.3.5 Office, Work Areas and Meeting Rooms
- Counters
- 5.3.7 Drinking Fountains
- 5.3.8 Lockers
- 5.4.1 Controls and Operating Mechanisms
- 5.4.2 Emergency Exits, Fire Evacuation and Areas of Rescue Assistance
- 6.7 Signage and Wayfinding
- 6.8 Detectable Warning Surfaces
- 6.9 Windows, Glazed Screens and Sidelights



Barriers and Obstacles

The accessibility of public spaces should provide freedom of movement for all persons. Traditionally such spaces have been designed for able-bodied pedestrians, and more recently have incorporated persons with physical disabilities, by providing such things as curb cuts and ramps.

Urban Braille is a system that further addresses issues facing persons with visual impairments and conveys:

- Sidewalk, road boundaries;
- Hierarchy of Clearways;
- Directional Change (compass N. S. E. W.);
- Entrances to significant buildings.

It is intended that the system be implemented in high pedestrian traffic areas. It is also recommended that this system be installed in semi-public spaces, providing safe and accessible pathways between the street and the facility (e.g., between parking lots, entrances, and municipal sidewalks).

Design Requirements

- 1) Any Urban Braille in the City of Hamilton shall comply with the City of Hamilton's Urban Braille system design guidelines.
- 2) Urban Braille guidelines as defined by the City of Hamilton shall be provided in semi-public spaces for civic buildings.

It is recommended that Urban Braille be implemented in semi-public spaces for any facility open to a high level of pedestrian traffic.

- 3) A clearway - **Figure 6.5(a)** - is an unobstructed path of travel for pedestrians - including those using mobility aids- to bypass each other, and shall:
 - a) have a clear and unobstructed path of travel:
 - i) with all street furniture and planting located outside of the clearway boundaries; and
 - ii) in a preferred straight line of travel;
 - b) have a smooth and even surface;
 - c) where space allows, be bounded by a shoreline on either side of the clearway;

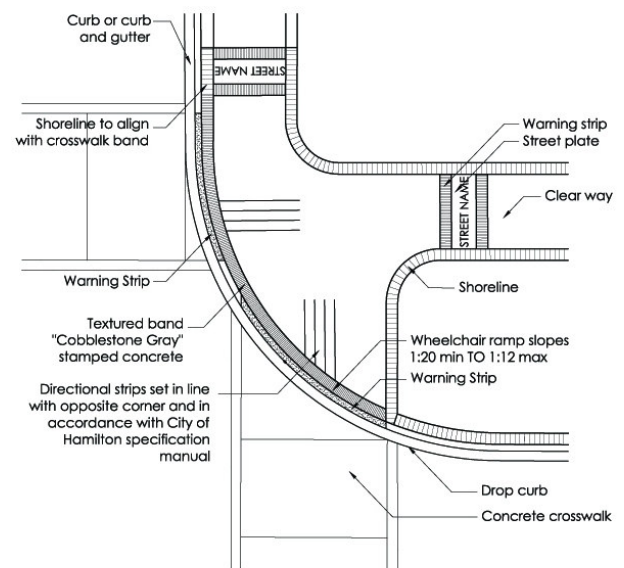

Note: Refer to current City of Hamilton urban braille documents for specifics

Figure 6.5(a)
Curb Ramp and Directional Strips



- d) have a clear width of a minimum of 1500 mm (59 in.) measured inside the shorelines;
- e) where the clear width is less than 1500 mm (59 in.) be bound by a single shoreline at the edge adjacent to the road; and
- f) be unpigmented, regular concrete.
- 4) **Shorelines – Figure 6.5(b)** - define the limit of a clearway and/or the edge at the curb/road, and shall:
- be a minimum of 150 mm (6 in.) and where possible be 230 mm (9 in.) wide or an approved equivalent;
 - be dark grey in colour;
 - be stamped with a single row of soldier course brick pattern;
 - define both edges of a clearway. If space is limited a shoreline should indicate the edge adjacent to the road.
- 5) **Street Name Sidewalk Plates – Figure 6.5(c)** - indicate the street name perpendicular to the path of travel, and shall:
- be located on all corners to indicate intersecting streets;
 - have lettering typically oriented to be read while facing the intersecting street;
 - be approximately 610 mm (24 in.) high and bounded on either side by a 230 mm (9 in) textured band (i.e., warning strip);
 - have a width determined by the width of the clearway; and
 - have 200 mm (10 in.) high letters, recessed, centred, and highlighted with black pigment – font style typically Bookman Old Style or approved equivalent.
- 6) **Decision Node symbols - Figure 6.5(d)** - indicate more than one route of travel (e.g., major building entrances, stairways, minor pathways, or an event), and shall:
- be impressed:
 - unpigmented concrete;
 - 600 mm x 600 mm (23-1/2 in. x 23-1/2 in.) diamond-shaped marker; and
 - have a 25 mm x 25 mm (2 in. x 2 in.) textured grid; and
 - be located on centre of the path of travel.

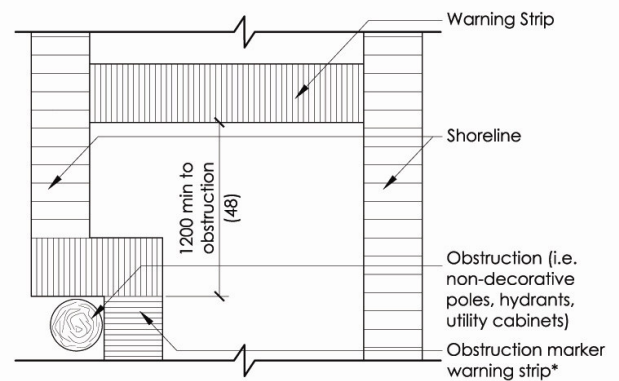

Note: Refer to current City of Hamilton Urban Braille documents for specifics

* Obstruction marker not required around decorative pole

Figure 6.5(b)
Shorelines & Obstruction Marker

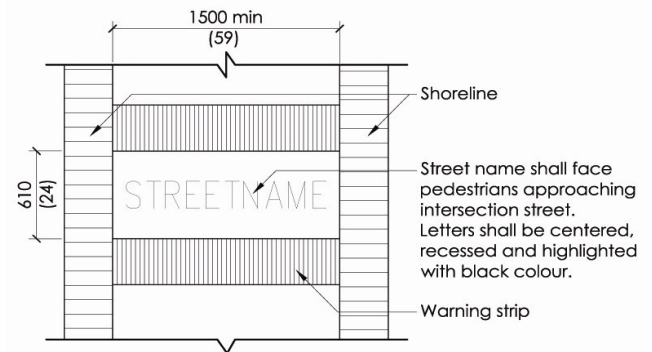

Note: Refer to current City of Hamilton urban braille documents for specifics

Figure 6.5(c)
Sidewalk Plate

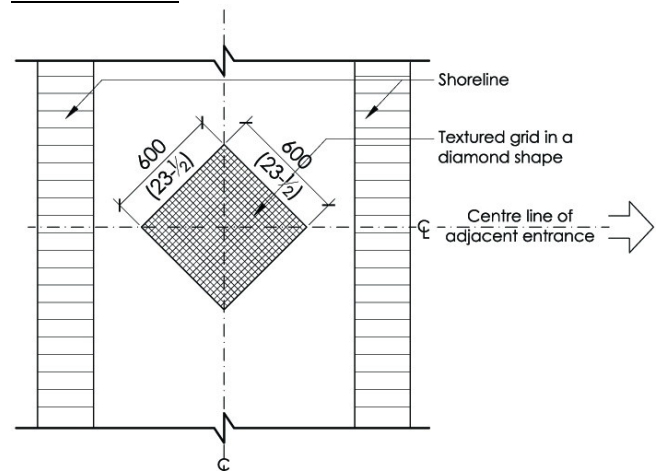

NOTE: REFER TO CURRENT CITY OF HAMILTON URBAN BRAILLE DOCUMENTS FOR SPECIFICS

Figure 6.5(d)
Decision Node Symbol



- 7) A Bus Stop Detection Strip - **Figure 6.5 (e)** - indicates proximity of bus stops and/or bus shelters and shall:
- have a band width of 450 mm (18 in.);
 - be of a dark grey concrete colour ;
 - be stamped with a double row of soldier course banding;
 - be located perpendicular to the walkway, extending from the outer shoreline, through the clearway, through a boulevard – if present – to the curb;
 - be subject to the design of the transit stop, which shall be approved by the City of Hamilton prior to installation.
- 8) A Warning Strip - **Figure 6.5(f)** - provides clear tactile warning of imminent and potential conflict and shall:
- comprise a band:
 - 230 mm (9 in.) wide of impressed concrete with tactile lines perpendicular to the band;
 - perpendicular to, and between the shorelines, through a given clearway; and
 - unpigmented, regular concrete;
 - be located:
 - at the start and end of driveway approaches with an offset of 1200 mm (47 in);
 - at corners parallel to and behind the curb within the limit of wheelchair ramps;
 - perpendicular to roadways where there is no Street Name Sidewalk Plate; and
 - perpendicular to the roadway in front of decision node symbols.
- 9) Corner Curbs and Ramps – Refer to Section 5.1.5 *Exterior Pedestrian Routes*.
Where Urban Braille is implemented provide a 'Warning Strip' at corners parallel to and behind the curb within the limit of the ramp;

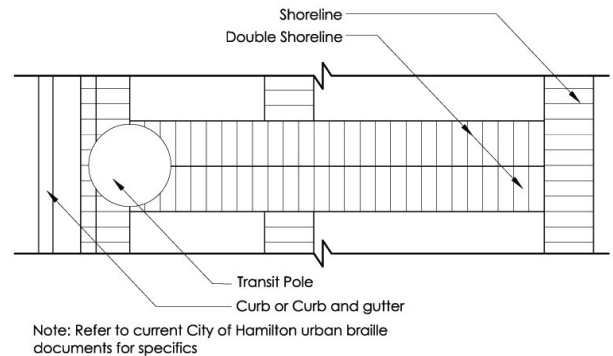

Figure 6.5(e)
Transit Stop Treatment

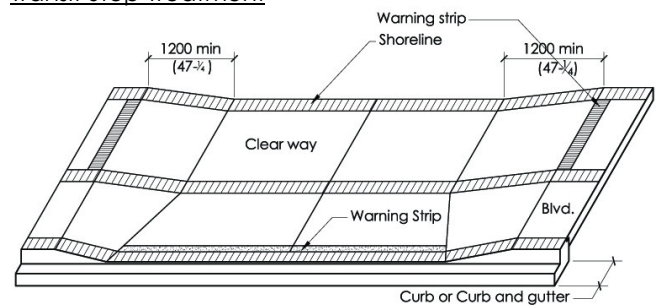

Figure 6.5(f)
Driveway Traverse "Warning Strip" Locations



- 10) Annual Flower Beds:
- a) may be located between the shoreline of the clearway and the curb edge;
 - b) shall be located level with the sidewalk with:
 - i) a consistent 100 mm (4 in.) high by 250 mm (10 in.) wide rolled concrete edge; and
 - ii) the colour at the edge to match the adjacent concrete colour.
- 11) Accent Areas:
- a) is space provided which would house obstacles such as patios, benches, flower beds, street trees, parking meters, bike and parking standards and street furniture in general, which should not encroach on the clearway; and
 - b) may be provided as additional and adjacent to the clearway.
- 12) Parking / Taxi / Bus Waiting Zone
- a) Delineated as the sidewalk between outer shoreline and curb face i.e., the boulevard that is a separate area from the clearway.
 - b) Colour is unpigmented regular concrete.
 - c) May contain obstacles such as bus shelters, light standards, trees, parking meters, etc.

Related Sections

- 5.1.4 Accessible Routes, Paths and Corridors
- 5.1.5 Exterior Pedestrian Routes
- 5.4.1 Controls and Operating Mechanisms
- 6.4 Texture and Colour



Barriers and Obstacles

Information systems that are provided for the public should:

- have an alternate method such as audio supplying the information; and
- be located in such a way that individuals in wheelchairs or scooters when seated shall be at eyelevel with the information.

Design Requirements

- 1) Where information is provided via video display, it must also be available in a format such as audio or Braille.
- 2) Systems for direct access shall be located at a suitable height for individuals using wheelchairs or scooters.
- 3) Print shall be:
 - a) large text (minimum of 16 point);
 - b) in high contrast with the background; and
 - c) available in other formats such as audio or Braille.
- 4) Push button controls used for accessing public information systems shall:
 - a) be clearly identifiable using colour or tone;
 - b) have raised numbers, numerals or symbols; and
 - c) have tactile identification in compliance with section 6.4 *Texture and Colour*.

Related Sections

- 5.4.1 Controls and Operating Mechanisms
- 6.4 Texture and Colour



Barriers and Obstacles

Signage is an important part of navigating buildings and facilities. When planning signage, consideration should be taken in regards to:

- keeping the sign simple, uncluttered;
- incorporating plain language;
- the usage of graphic symbols to simplify signs;
- contrasting colour;
- ensuring the intent of the sign is clear and universal; and
- tactile lettering or graphics which may incorporate edges that are slightly smooth.

Design Requirements

- 1) Signage shall:
 - a) be of consistent shape, colour, position and height when locating a specific facility or service;
 - b) be placed to avoid glare and/or shadows;
 - c) be placed at decision-making points on a path of travel (e.g., exits, entrances, etc.);
 - d) face the direction of travel;
 - e) locate appropriate accessible parking;
 - f) be visible from the street or public lane way when marking a street address or facility name;
 - g) be at a height which is visible even when snow is piled near by;
 - h) mark pedestrian, vehicular and emergency routes; and
 - i) where located near a doorway, be adjacent to the latch side of the door. The centre line of such signage shall be between 1475 mm and 1525 mm (58 in. and 60 in.) above the finished floor.
- 2) The International Symbol of Accessibility shall identify:
 - a) parking spaces;
 - b) accessible loading zones;
 - c) accessible entrances where not all entrances are accessible;
 - d) toilet and bathing facilities where not all are accessible;



- e) accessible telephones;
 - f) elevators and elevating devices;
 - g) accessible means of egress; and
 - h) accessible areas of rescue assistance.
- 3) Letters and numerals on signs shall:
- a) be "sans serif" font. Numbers shall be standard Arabic numerals;
 - b) have a width to height ratio of 3:5 to 1:1;
 - b) have a stroke width to height ratio of 1:5 to 1:10;
 - c) be in contrasting colour of a minimum of 70% with the background colour;
 - d) be in accordance to **Table 6.7** in regards to the character height relative to the intended viewing area;
 - e) have a mixture of capitals and lower case letters (e.g., Hamilton) where applicable;
 - f) be of eggshell, matte or other glare free finish;
 - g) where possible, vertical lettering should be avoided; and
 - h) move at a slow speed on scrolling signs.
- 4) Tactile Signs:
- a) may supplement the text of regulatory, warning and identification signs.
 - b) Overhead signs do not need to be tactile as they cannot be reached.
 - c) Tactile characters shall be:
 - i) raised 0.8 mm to 1.5 mm (1/32 in. to 1/16 in.);
 - ii) 16 mm to 50 mm (5/8 in. to 2 in.) in height;
 - iii) accompanied by grade one Braille near the lower edge of the sign; and
 - iv) in a contrasting colour of a minimum of 70% with the background colour.
 - d) Pictograms shall be:
 - i) raised 0.8 mm to 1.5 mm (1/32 in. to 1/16 in.);
 - ii) a minimum of 150 mm (6 in.) in height;
 - iii) accompanied by grade one Braille near the lower edge of the sign; and
 - iv) in a contrasting colour of a minimum of 70% with the background colour.
- 5) The level of illumination where incandescent lighting is required shall be 200 lux (20 ft-candles).

Minimum character height, mm	Maximum viewing distance, mm
200 (7- ⁷ / ₈ in.)	6000 (19 ft. 8 in.)
150 (5- ⁷ / ₈ in.)	4600 (15 ft. 0 in.)
100 (3- ⁵ / ₁₆ in.)	2500 (8 ft. 2- ¹ / ₂ in.)
75 (2 in.)	2300 (7 ft. 6- ¹ / ₂ in.)
50 (2 in.)	1500 (4 ft. 11 in.)
25 (1 in.)	750 (2 ft. 5- ¹ / ₂ in.)

Table 6.7
Character Height on Signs



Related Sections

- 5.1.4 Accessible Routes, Paths and Corridors
- 5.1.8 Entrances
- 5.1.9 Doors
- 5.1.10 Gates, Turnstiles and Openings
- 5.1.12 Ramps
- 5.1.16 Elevators
- 5.1.17 Platform Lifts
- 5.2.1 Toilet and Bathing Facilities
- 5.2.6 Individual Washrooms
- 5.3.2 Public Telephones
- 5.4.2 Emergency Exits, Fire Evacuation and Areas of Rescue Assistance
- 6.4 Texture and Colour





Barriers and Obstacles

Detectable warning surfaces should be used to alert individuals with visual impairments of potential hazards. A change in texture or colour, which does not produce a tripping hazard, shall be used consistently to mark specific areas.

Design Requirements

Detectable warning surfaces - **Figure 6.8(a)** - shall be:

- 1) cane detectable;
- 2) visually contrasting with surrounding area;
- 3) provided at top of stairs and at landings;
- 4) the full width of the stairs;
- 5) a minimum width of 915 mm (36 in.); and
- 6) present where walkways adjoin with road or vehicular ways where there is no other separation.

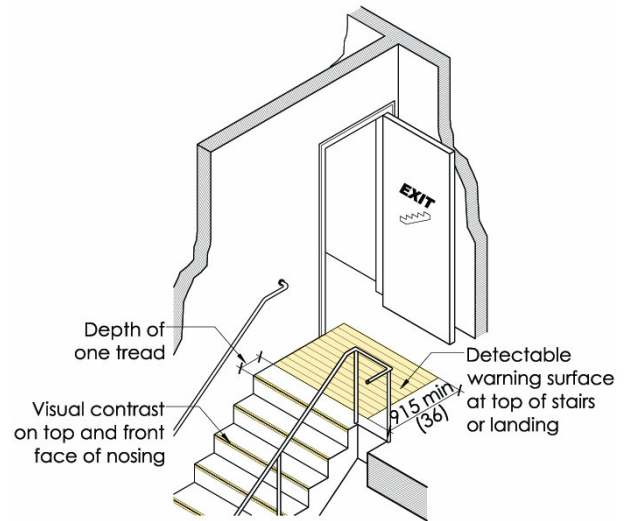

Figure 6.8(a)
Detectable Warnings at Stairs

Related Sections

- 5.1.4 Accessible Routes, Paths and Corridors
- 5.1.8 Entrances
- 5.1.9 Doors
- 5.1.10 Gates, Turnstiles and Openings
- 5.1.12 Ramps
- 5.1.13 Stairs
- 5.1.16 Elevators
- 5.1.17 Platform Lifts
- 5.2.1 Toilet and Bathing Facilities
- 5.2.6 Individual Washrooms
- 5.3.2 Public Telephones
- 5.4.2 Emergency exits, Fire Evacuation and Areas of Rescue Assistance
- 6.4 Texture and Colour



Barriers and Obstacles

Windows, glazed screens and sidelights can be difficult to see. Precautions must be taken to prevent individuals from walking into the glass. Individuals who have limited reach need blind and louver controls at a lower level. Limited hand dexterity should also be considered when choosing window controls.

Design Requirements

- 1) Fully glazed sidelights or screens shall be clearly identified with a horizontal stripe or row of decals.
 - a) The horizontal stripe - **Figure 6.9(a)** - shall:
 - i) be a minimum of 50 mm (2 in.) in width;
 - ii) be contrasting in colour;
 - iii) have a centre line of 1475 mm to 1525 mm (58 in. to 60 in.) in height from the finished floor surface; and
 - iv) have a second horizontal stripe or row of decals that has a centre line of 1170 mm to 1220 mm (46 in. to 48 in.) from the finished floor surface.
 - b) Decals shall:
 - i) have a maximum distance of 150 mm (6 in.) from centre to centre;
 - ii) be either a 50 mm (2 in.) square, circle or special design;
 - iii) be contrasting in colour to the surrounding environment; and
 - iv) be provided even where etched or patterned glass is used.
- 2) Frameless glass shall have the exposed edges identified with a vertical stripe to cap the end glass panel.
- 3) Windows shall:
 - a) have a maximum sill height of 765 mm (30 in.) - **Figure 6.9(b)**;
 - b) not have vertical mullions between 1060 mm and 1220 mm (41 3/4 in. and 48 in.) above finished floor, to avoid blocking the vision of an individual in a wheelchair or scooter;

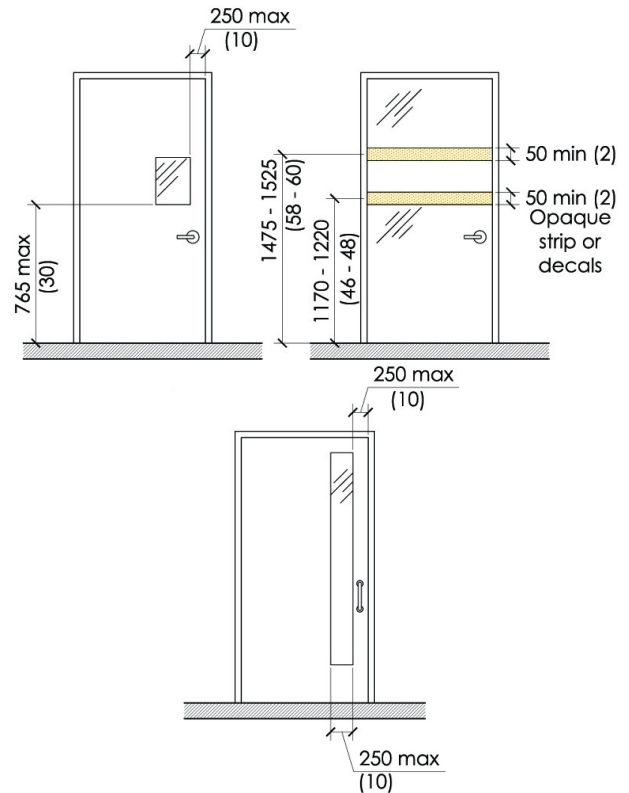

Figure 6.9(a)
Door Window Patterns

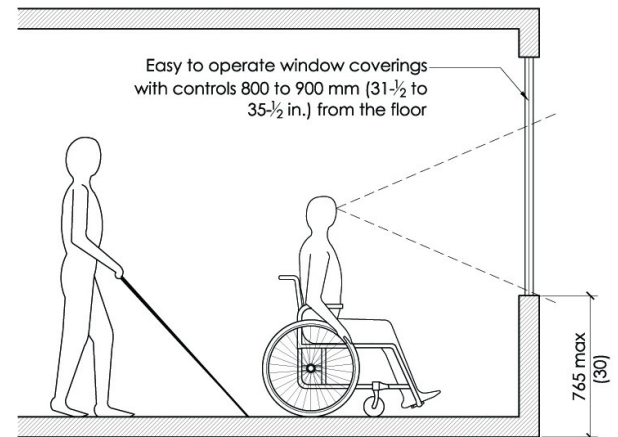

Figure 6.9(b)
Window Sill Height



- c) have hardware located between 400 mm and 1200 mm (15-3/4 in. and 47 in.); and
- d) have hardware that is operable by using only one hand, and does not need fine finger movement, tight grasping, pinching or twisting to operate.

Related Sections

- 5.1.1 Space and Reach Requirements
- 5.4.1 Controls and Operating Mechanisms



Life expectancy has increased globally and with it we are faced with providing for a population of seniors and their typical maladies, such as a loss of hearing.

Consideration of sound systems, acoustic design and current technologies will provide for inclusive society.

This section deals with the design and provision of requirements for universal access, notwithstanding audible limitations.

7.0.

- 1 Acoustics
- 2 Public Address Systems
- 3 Audible Signals
- 4 Assistive Listening Systems
- 5 Visual Alarms



Barriers and Obstacles

Acoustics in public buildings should be accommodative to individuals with various hearing impairments.

- Individuals should be able to differentiate background noise.
- Occasional noises should not be unduly amplified.

Design Requirements

- 1) Floor finishes, wall surfaces, ceilings and other large surfaces shall be selected so noise will not be excessively amplified.
- 2) At larger facilities, measures should be taken to aurally differentiate sound transmission or reflection for major and secondary paths of travel at accessible routes.
- 3) Echoes should be avoided when determining ceiling shapes - Domed ceilings are prone to distort sound.
- 4) Public address and call systems shall be zoned to key areas. Refer to section 7.2 *Public Address Systems*.
- 5) Unnecessary background noise such as mechanical equipment, fans and air diffusers should be minimised with adequate sound insulation in meeting rooms and assembly areas.

Related Sections

- 5.2.2 Public Telephones
- 5.2.4 Information, Reception and Services Counters
- 5.2.5 Office, Work Areas and Meeting Rooms
- 7.4 Assistive Listening Systems



Barriers and Obstacles

Public Address Systems should be used to accommodate individuals with hearing impairments. In order to utilise these systems, background noises, such as mechanical noises or music, should be minimised wherever possible.

Design Requirements

- 1) To aid individuals with hearing or visual limitations, public address systems shall be easily heard above background noise without distortion or feedback.
- 2) Public address speakers shall:
 - a) be mounted above head level;
 - b) have effective sound coverage in areas such as corridors, assembly areas and meeting rooms, recreational and entertainment facilities; and
 - c) be used in institutional common areas.
- 3) Public address systems shall be zoned as to:
 - a) allow information to be directed to key locations; minimising undue background noise in other locations; and
 - b) allow for background music in certain areas only. The music should:
 - i) not be broadcast continuously; and
 - ii) broadcast throughout the entire facility; and
 - c) have the ability to shut off certain zones.
- 4) All-point call systems shall be used only for fire or emergency information.
- 5) Other call systems, such as personal alarm or paging systems, shall be used with care according to the requirements of the user.
- 6) Paging systems shall be discreet and low in volume.

Related Sections

- 5.4.2 Emergency Exits, Fire Evacuation and Areas of Rescue Assistance
- 7.1 Acoustics





Barriers and Obstacles

Audible signals are beneficial not only to individuals with visual impairments. These systems should have distinctive tones or pulses to indicate when there is a problem and when to evacuate the building.

Design Requirements

- 1) Audible signals, such as fire alarms and elevator arrival signals shall be loud and distinct, as to be heard over normal background noise.
- 2) Public buildings or institutions providing services to seniors or individuals with disabilities should have a two-stage alarm system. One tone should indicate that there is a problem; a second tone should indicate when to evacuate the building.
- 3) Audible signals should be accompanied by visual alarms.
- 4) Portable vibrating alarms may be considered where an individual has both hearing and visual impairments.

Related Sections

- 5.4.2 Emergency Exits, Fire Evacuation and Areas of Rescue Assistance
- 7.1 Acoustics



Barriers and Obstacles

Assistive listening systems are important devices for individuals who have difficulty hearing. Where assistive listening systems are provided, other considerations should be taken, such as:

- adequate and controllable light for individuals to lip read; and
- increased task lighting for those with visual impairments.

Design Requirements

- 1) Assistive listening systems should be permanently installed in assembly areas where:
 - a) the assembly area accommodates 50 people or more;
 - b) there is an audio amplification system;
 - c) the floor area of the assembly area is greater than 100 sq. m (1076 sq. ft.); and
 - d) there is fixed seating.
- 2) In assembly areas, at least 4%, but no less than two, of the total number of seats shall be provided with receivers.
- 3) Signage in compliance with section 6.7 *Signage and Wayfinding* shall be located where assistive listening systems are provided.
- 4) Acceptable types of assistive listening systems include:
 - a) infrared systems;
 - b) induction loops; and
 - c) F.M. radio frequencies.
- 5) Where an induction loop system is provided:
 - a) dimmer switches and other controls that contain transformer coils shall be located so as to not interfere with the audio induction loop; and
 - b) at least half of the seating area shall be encompassed by the system.
- 6) Where infrared systems are provided, overhead incandescent lights shall be located so as to not cancel out infrared signals at the receiver.
- 7) Portable headsets shall be provided where assistive listening systems are provided.



- 8) Where listening systems serve an assembly area with fixed seats:
- a) the affected seats shall be no further than 15 m (49 ft. 2-1/2 in.) in viewing distance from the stage or playing area; and
 - b) the seats shall have an unobstructed view of the stage or playing area.

Related Sections

- 6.2 Lighting
- 6.7 Signage and Wayfinding
- 7.1 Acoustics



Barriers and Obstacles

Visual alarms usually consist of flashing lights. These lights are beneficial for individuals who cannot hear the audible signals, or who need to see the lights to find their way out.

Design Requirements

- 1) Flashing lights which are incorporated into a visual alarm system should:
 - a) correspond with the audible emergency alarm systems;
 - b) flash at a frequency rate of 1-3 Hz to minimise the risk of epileptic seizure;
 - c) be synchronised to flash at the same time as each other;
 - d) be significantly brighter than regular ambient lighting.
- 2) Visual alarm systems shall be:
 - a) xenon strobe or equivalent;
 - b) of clear or normal white in colour;
 - c) a minimum brightness of 75 candela;
 - d) equipped with a maximum pulse duration of 0.2 seconds, so as not to hinder anyone's sight lines;
 - e) capable of a maximum of a 40% duty cycle; and
 - f) located either 2030 mm (80 in.) from the finished floor area or 152 mm (6 in.) from the ceiling, which ever is lower.
- 3) Where a room or space is required to have a visual alarm, the alarm units should be no further than 15 m (49 ft. 2-1/2 in.) apart.
- 4) In rooms greater than 30 m (98 ft. 5 in.) across, with no obstructions 2000 mm (78-3/4 in.) above finished floor, visual alarm devices may be placed around the perimeter, spaced at a maximum of 30 m (98 ft. 5 in.) apart instead of ceiling hung appliances.

Related Sections

- 5.4.2 Emergency Exits, Fire Evacuation and Areas of Rescue Assistance
- 7.1 Acoustics



Special Facilities and Areas 8.0

Some buildings or facilities are very specialised in their design and as a result, require specific consideration for 'universal access'.

The specific facility types listed in this Section shall, as well as complying with this document, fulfil the more stringent restrictions within additional design requirements specified in any other governing documents.

Where a facility contains more than one use covered by a special application section, each portion shall comply with the requirements for that section in addition to all other general provisions.

This section deals with issues of universal access specific to certain types of facilities or buildings.

8.0

- 1 Meeting Rooms, Assembly Areas and Theatres
- 2 Display, Exhibition Areas, Galleries and Museums
- 3 Outdoor Recreation Facilities
- 4 Municipal Courts
- 5 Gymnasiums
- 6 Libraries
- 7 Cafeterias, Restaurants, Dining Areas and Bars
- 8 Arenas
- 9 Ice Rink
- 10 Swimming Pools
- 11 Police Stations
- 12 Long Term Care Facilities and Senior's Housing
- 13 Clinics
- 14 Residential Kitchens
- 15 Residential Bathrooms
- 16 Residential Bedrooms
- 17 Transit Facilities
- 18 Airports





Barriers and Obstacles

Meeting rooms, assembly areas and theatres should be accommodating to everyone, regardless of their various disabilities.

Design Requirements

- 1) All meeting rooms, assembly areas and theatres should be accessible, regardless of varying impairments, if intended to be used by the general public, tenants or visitors to a specific building.
- 2) A minimum of 1% of fixed seating but not less than one seat in assembly areas, meetings rooms and theatres shall:
 - a) be an aisle seat with no armrests, or with removable arm rests; and
 - b) have a sign or marker which identifies the seat as accessible.
- 3) Accessible wheelchair or mobility aid seating locations - **Figure 8.1(a)** - shall be:
 - a) distributed throughout the meeting room, assembly area or theatre to allow for various admission prices as well as various vantage points;
 - b) located in a clear and level space. A removable seat may be provided when the accessible space is not required;
 - c) a minimum of 915 mm (36 in.) wide and 1525 mm (60 in.) long where the wheelchair or scooter is required to enter the space from the side;
 - d) a minimum of 915 mm (36 in.) wide and 1370 mm (54 in.) long where the wheelchair or scooter is required to enter the space from the front or rear;
 - e) arranged so a minimum of two designated wheelchair locations are positioned side by side;
 - f) arranged so at least one fixed seat is located adjacent to each designated accessible location;
 - g) in conformance with **Table 8.1**, when the seating capacity of the meeting room, assembly area or theatre exceeds 100; and
 - h) guard rails protecting wheelchair viewing spaces should not interfere with viewing.
- 4) Elevated platforms such as stage areas or speaker podiums shall:
 - a) be located on an accessible route;
 - b) have the capacity to be illuminated to a minimum of 100 lux (9 ft-candles) at the darkest point;

Number of Fixed Seats in Seating Area	Minimum number of Spaces Required for Wheelchairs
Up to 100	2
101 to 200	3
201 to 300	4
301 to 400	5
401 to 600	6
Over 600	Not less than 1% of the seating capacity

Table 8.1
Wheelchair Viewing Locations

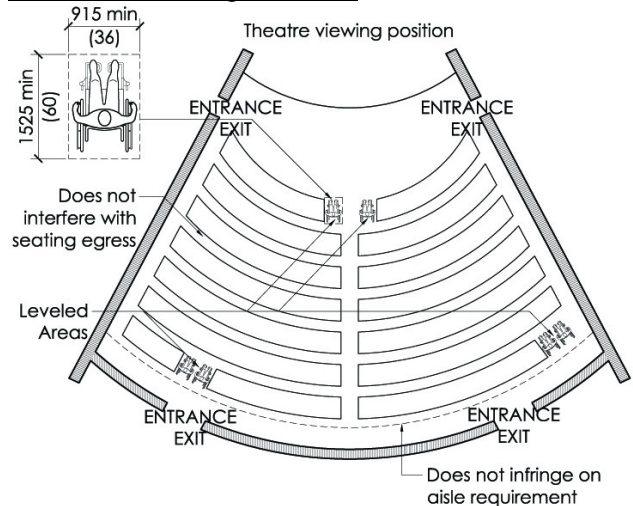

Figure 8.1(a)
Theatre Viewing Locations

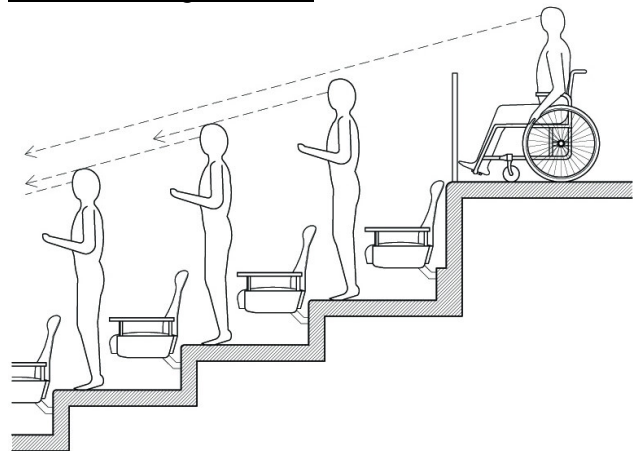

Figure 8.1(b)
Sight Lines at Wheelchair Locations



- c) be of sufficient size to safely accommodate mobility aids such as scooters and wheelchairs; and
- d) have detectable warning surfaces on non-railing edges that:
 - i) comply with section 6.8 *Detectable Warning Surfaces*;
 - ii) run parallel to the open end of the platform;
 - iii) run the full length of the platform; and
 - iv) are a depth of 610 mm to 915 mm (24 in. to 36 in.)
- 5) Handrails shall be provided on the outer walls of auditorium seating areas. Refer to 5.1.14 *Handrails*.
- 6) All meeting rooms, assembly areas and theatres shall be accommodating to individuals with varying visual and audible disabilities.
 - a) Major signs (e.g., room names) should be provided in both large print and Braille in accordance with section 6.7 *Signage and Wayfinding*.
 - b) Areas, where possible, shall be lit with indirect lighting, in accordance with section 6.2 *Lighting*.
 - c) Display screens or other audio-visual equipment shall be positioned so as to allow for optimum visibility.
 - d) Where required, assistive listening systems shall be provided in all meeting rooms, assembly areas and theatres in accordance with section 7.4 *Assistive Listening Systems*.
- 7) Meeting rooms, assembly areas and theatres shall have acoustics in compliance with section 7.1 *Acoustics*.
- 8) All meeting rooms, assembly areas and theatres shall have a sign in conformance with section 6.7 *Signage and Wayfinding* indicating the intended use of the room. (e.g., 'Meeting Room A')

Related Sections

- 5.1 Access and Circulation
- 5.2 Washroom Facilities
- 5.3 Amenities
- 5.4 Systems and Controls
- 6.0 Visual Accessibility
- 7.0 Audible Accessibility



Barriers and Obstacles

Displays, exhibition areas, galleries and museums are used by a variety of individuals with a variety of abilities. Consideration should be given when placing items on display so that they may be enjoyed by as many people as possible.

Design Requirements

- 1) All exhibits or displays should be displayed so individuals with various disabilities may access, enjoy and understand them.
- 2) Displays, exhibition areas, galleries and museums should be accessible to individuals who use mobility aids.
 - a) Aisles between exhibits shall be no less than 1065 mm (42 in.) wide;
 - b) Horizontal or inclined cases shall be no taller than 915 mm (36 in.); and
 - c) Include a knee space of at least 700 mm (27-1/2 in.).
- 3) Tactile exhibits should have information nearby which is printed in large text, Braille, or available in audiotape.
- 4) Audio exhibits should consider compatibility with hearing aids. Audio exhibits should have written information available nearby.
- 5) Lighting in displays, exhibition areas, galleries and museums shall conform to section 6.2 *Lighting*. Consideration should also be given to:
 - a) minimising glare on display cases, and
 - b) enhancing key locations for exhibit enjoyment.

Related Sections

- 5.1.4 Accessible Routes, Paths and Corridors
- 5.1.9 Doors
- 6.1 Glare and Light Sources
- 6.2 Lighting
- 6.7 Signage and Wayfinding
- 7.1 Acoustics





Barriers and Obstacles

Outdoor recreational facilities include:

- boardwalks;
- docks;
- outdoor pools;
- trails and footbridges;
- pathways;
- rest areas;
- parks;
- play equipment;
- picnic areas;
- waterfront areas;
- natural areas; and
- playing fields.

Design Requirements

- 1) Where dressing facilities are provided for the use of the public using outdoor recreational facilities, a minimum of 50%, but no less than one male and one female dressing facilities shall be accessible.
- 2) **Boardwalks** that are provided for the use of the general public shall:
 - a) be a minimum width of 2440 mm (96 in.);
 - b) consist of firm, non slip materials;
 - i) if wooden planks are used, they shall be laid in the opposite direction of the path of travel; and
 - ii) there shall be no joints greater than 6 mm (1/4 in.).
 - c) incorporate a continuous raised edge where there is a drop off that is 200 mm (8 in.) or greater;
 - i) the continuous raised edge shall be a minimum of 100 mm (4 in.) and of contrasting colour.
 - d) include a hand rail, guard rail or other suitable barrier where there is a drop off of 450 mm (18 in.) or greater;
 - e) where street furniture is provided, it shall be located adjacent to the boardwalk, on a firm, level surface which is level with the surface of the boardwalk.



- 3) **Docks** intended for fishing, boating or swimming shall:
 - a) be located on an accessible route in conformance with section 5.1.4 *Accessible Routes, Paths and Corridors*;
 - b) incorporate ramps or curb ramps as per section 5.1.12 *Ramps*;
 - c) incorporate a continuous raised edge where the average water level is 200 mm (8 in.) or more below the dock surface;
 - d) include a hand rail, guard rail or other suitable barrier where the average water level is 450 mm (17-3/4 in.) or more below the dock surface; and
 - e) incorporate colour contrasting handrails where steps are provided to access the water for swimming.
- 4) **Outdoor pools** shall conform to section 8.11 *Swimming Pools*.
- 5) **Trails and footbridges** should:
 - a) ideally be sloped no greater than 1:20 or have adjacent ramps and steps; and
 - b) where incorporating steps, footbridges or ramps, be constructed out of non-slip materials, and include suitable colour-contrasting handrails and/or guardrails.
- 6) **Pathways:**
 - a) shall conform to section 5.1.4 *Accessible Routes, Paths and Corridors*.
 - b) Where street furniture is provided, it shall be located adjacent to the pathway in conformance with section 5.3.1 *Street Furniture*.
 - c) Change in texture and/or colour shall indicate:
 - i) risk areas (e.g., intersections, ramps or steps); and
 - ii) functional changes such as seating areas, view points or outlooks.
- 7) **Rest areas** shall:
 - a) be provided adjacent to trails, pathways and walkways;
 - b) be accessible ground surfaces in accordance with section 5.1.2 *Ground and Floor Surfaces*;
 - c) identify function change by contrasting ground finish; and
 - d) incorporate a minimum of one bench per rest area.



8) Parks

- b) Entrance gates, paths and walkways shall be accessible to individuals using mobility aids such as wheelchairs and scooters.
- c) Play areas should be located in both sunny and shady areas.
- d) Play equipment shall be:
 - i) designed to be used by children of varying abilities and disabilities - **Figure 8.3(a)**;
 - ii) on an accessible route where usable by individuals with varying disabilities; and
 - iii) located on a surface which is firm, level and drains rapidly.

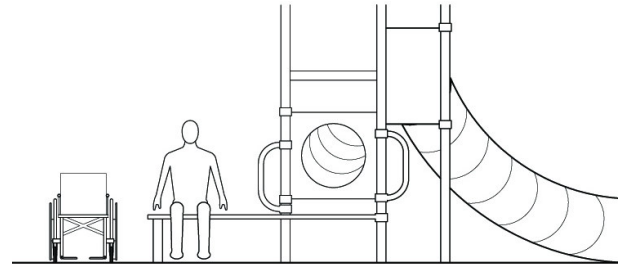

Figure 8.3(a)
Children Play Area Example

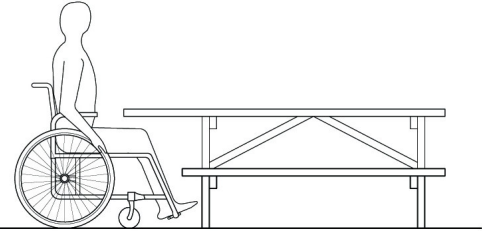

Figure 8.3(b)
Accessible Picnic Table

9) Picnic Areas - **Figure 8.3(b)**:

- a) shall be available in a variety of sunny and shady locations on an accessible route.
- b) At least 50% of, but no less than one, picnic tables shall:
 - i) be on an accessible route in conformance with section 5.1.4 *Accessible Routes, Paths and Corridors*
 - ii) be constructed so that an individual using a mobility aid such as a wheelchair may approach from either one or both ends; and
 - iii) provide adequate knee space and arm rest space.

10) Waterfront Areas

- a) Paths or lookout areas shall be accessible to all individuals.
- b) Seating shall be provided along look out points and paths.

11) Natural Areas

- a) Where the surrounding environment permits, accessible pathways trails and footbridges should be provided.
- b) Rest areas with accessible seating should be incorporated along paths, and trails.
- c) Wild life viewing areas shall have clear signage.
- d) A tactile map shall be located at the beginning and periodically throughout trails.
- e) Signage or written information should also be available in Braille.

**12) Playing Fields**

- a) Controlled access points, such as turnstile gates shall accommodate individuals using mobility aids such as wheelchairs and scooters.
- b) Level seating areas should be provided beside sporting fields for players and spectators with disabilities.

13) Along with related sections in this book, when designing outdoor recreational facilities, consideration should be also given to:

- animal settings;
- fences and enclosures;
- gardens;
- ground covers and surfacing;
- land forms and topography;
- management for play settings;
- manufactured play equipment;
- multipurpose games;
- trees and vegetation; and
- water and sand settings.

Related Sections

- 5.1.1 Space and Reach Requirements
- 5.1.2 Ground and Floor Surfaces
- 5.1.3 Protruding Objects
- 5.1.4 Accessible Routes, Paths and Corridors
- 5.1.5 Exterior Pedestrian Routes
- 5.1.12 Ramps
- 5.1.13 Stairs
- 5.1.14 Handrails
- 5.3.1 Street Furniture
- 6.1 Glare and Lighting Sources
- 6.2 Lighting
- 6.5 Urban Braille
- 6.7 Signage and Wayfinding



Barriers and Obstacles

Municipal Courts need to be accessible to all individuals regardless of their abilities or disabilities.

Design Requirements

- 1) In addition to section 5.1.8 *Entrances*, at least one restricted and secured entrance shall be accessible.
 - a) Secured entrances operated by security personnel need not be accessible.
- 2) Where security barriers restrict access, such as metal detectors, an accessible route shall be provided adjacent to barriers.
- 3) Where two-way communication devices are provided to gain access to a facility, the device shall provide both audible and visual signals.
- 4) Elements and spaces which are to be on an accessible route in compliance with 5.4.1 *Controls and Operating Systems* are:
 - a) spectator, press and other areas with 25 fixed seats or less, and with a clear floor space in compliance with section 5.1.1 *Space and Reach Requirements*;
 - b) spectator, press and other areas with 25 fixed seats or more in compliance with section 8.1 *Meeting Rooms, Assembly Areas and Theatres*;
 - c) jury boxes and witness stands; and
 - d) judges' benches and courtroom stations, in compliance with section 5.3.6 *Tables, Counters and Work Surfaces*.
- 5) In a retrofit situation, wheelchair spaces may be provided outside of jury boxes and witness stands where a ramp or lift would create a hazard by restricting or projecting into a required means of egress.



- 6) Assistive listening systems shall be permanently installed in each courtroom in conformance with section 7.4 *Assistive Listening Systems*.
 - a) A minimum number of receivers shall be no less than 4% of the required occupant load, but no less than two.
 - b) Signage indicating the availability of assistive listening systems shall be located in a highly visible place.

Related Sections

- 5.1.5 Exterior Pedestrian Routes
- 5.2 Washroom Facilities
- 5.3 Amenities
- 5.4 Systems and Controls
- 6.0 Visual Accessibility
- 7.0 Audible Accessibility



Barriers and Obstacles

Gymnasiums have become very specialised and as a result they carry a significant construction cost. Many organisations rent their facilities in order to re-coup costs, and with this in mind designers should be aware of issues of universal design.

Flexibility of use is also important as gymnasiums sometimes double as auditoriums for dances or fundraisers, or theatres for performances. Consideration should be given to ease of access to storage (e.g., chairs and equipment, versatility of lighting and sound, etc.) for people setting up for events, as well as persons attending events as users and spectators.

Design Requirements

- 1) Gymnasiums, whether for educational or recreational purposes, shall be accessible to individuals with various disabilities.
- 1) The main floor, and/or exercise areas shall be fully accessible, including related:
 - a) change areas;
 - b) showers;
 - c) washrooms; and
 - d) locker areas.
- 2) Bleachers or seating areas, whether they are temporary or permanent shall:
 - a) be on a accessible route;
 - b) make provisions for wheelchairs (wherever possible offer a variety locations and views); and
 - c) provide stairs conforming to all applicable codes:
 - i) with a 25 mm (1 in.) vertical and horizontal colour contrasting strip at the nosing;
 - ii) with colour contrasting and tactile clues to define the width of the stairs; and
 - iii) with sufficient illumination.
 - d) wherever possible, provide additional handrails at centre aisles to assist persons using canes:
 - i) mounted in the middle of the aisle; and
 - ii) mounted so as not to obstruct sight lines.



- 5) Gymnasiums, in both the gymnasium area and the viewing area, shall have no obstacles which would hinder individuals with visual disabilities such as, but not limited to:
- e) unprotected floor slots;
 - f) underside of bleacher areas;
 - g) signs;
 - h) brackets; and
 - i) equipment protruding from walls as per 5.1.3 *Protruding Objects*.

Related Sections

- 5.0 Physical Accessibility
- 6.0 Visual Accessibility
- 7.0 Audible Accessibility



Barriers and Obstacles

To make libraries accessible, issues such as aisle width, shelf height, and accessibility of workstations and service counters must be addressed.

In addition, large print books should be made available on the first floor of the building to limit travel for seniors, people who are visually impaired and people who use mobility aids. Lighting should be sufficient so those with low vision are able to read without straining, and gratuitous noise should be limited so persons with hearing impairments may concentrate. Consideration of these matters allows for the ease of completing such activities as:

- looking through library stacks;
- working at provided workstations; and
- checking out or returning books.

Design Requirements

- 1) The clear aisle space among book stacks and card catalogues shall be in accordance with section 5.1.1 *Space and Reach Requirements*.
- 2) Aisle arrangement should allow enough clear floor space for a person using a wheelchair or scooter to make a 180-degree turn - **Figure 8.6(a)**.
- 3) At card catalogues, maximum reach heights shall comply with applicable segments of section 5.1.1 *Space and Reach Requirements*.
- 4) Shelves in stacks areas should be at a minimum low reach of 400 mm (15-3/4 in.) and at a maximum high reach of 1350 mm (53 in.) to allow for persons in wheelchairs, children, and persons of short stature to reach comfortably - **Figure 8.6(b)**.
- 5) Book stack lighting should be:
 - a) mounted directly over the aisle area; and
 - b) a minimum of 200 lux (20 ft-candles) at 915 mm (36 in.), from the finished floor.
- 6) A minimum of 10% of the supplied fixed seating (i.e., tables or study carrels) shall be accessible. If possible, all fixed furniture should be accessible.
- 7) A minimum of half of all computer catalogue or workstations shall be accessible. Provisions for Braille or large print should also be available.
- 8) Any fixed furnishings should be located on an accessible path in accordance with section 5.1.1 *Accessible Routes, Paths and Corridors*.

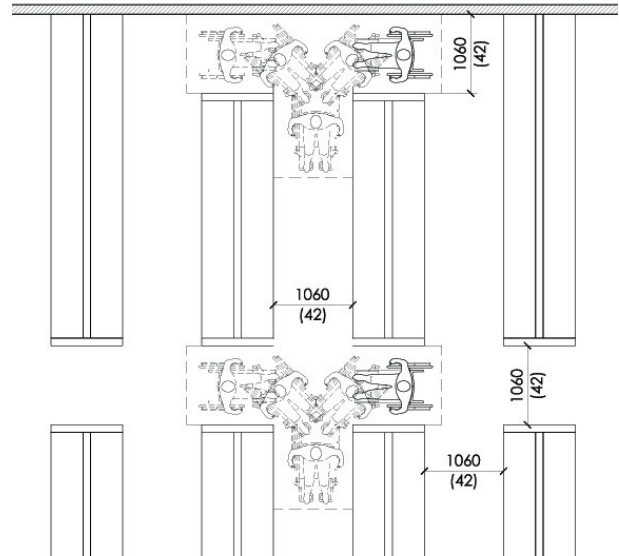

Figure 8.6(a)
Aisle Width

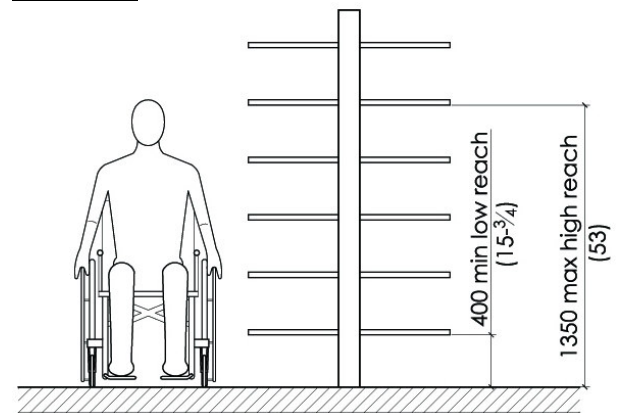

Figure 8.6(b)
Shelving Heights



- 9) There shall be a minimum of one moveable chair at every computer catalogue, computer workstation, or information or service counter.
- 10) Shelving over work areas should be a maximum of 1200 mm (47 in.) above the finished floor.
- 11) Study carrels should have:
 - a) knee clearance of 700 mm (27-1/2 in.) above finished floor;
 - b) an electrical outlet; and
 - c) a minimum light intensity of 100 lux (10 ft-candles) at the counter surface.
- 12) Computer catalogue or computer workstations should include:
 - a) a clear space for a person's knees and feet that complies with sections 5.1.1 *Space and Reach Requirements*, and 5.3.6 *Tables, Counters and Work Surfaces*;
 - b) a work surface at a maximum height of 865 mm (34 in.); and
 - c) a maximum table depth of 900 mm (35-1/2 in.).
- 13) In libraries where audio books, CDs, tapes, etc. are provided there should be a designated area where these materials may be used without disturbing others. Appropriate signage should clearly indicate this area.
- 14) A library's acoustic quality should be free of any unnecessary background noise that would compromise the comprehension of persons with hearing impairments.
- 15) All information or service desks shall comply with section 5.3.4 *Information, Reception and Service Counters*.
- 16) A minimum of one accessible lane shall be provided at each check out area. Where possible, all lanes should be accessible.
- 17) Traffic control or book security gates shall comply with section 5.1.10 *Gates, Turnstiles and Openings*.
- 18) Book drop slots shall be:
 - a) located on an accessible route complying with section 5.1.1 *Accessible Routes, Paths and Corridors*;
 - b) adjacent to a 2440 mm by 2440 mm (96 in. by 96 in.) level platform. In a retrofit situation where it is deemed infeasible to create a platform of this size, the dimensions may be reduced to 1525 mm by 1525 mm (60 in. by 60 in.);



- c) positioned between 860 mm and 915 mm (34 in. and 36 in.) above the floor; and
- d) operable with one hand.

Related Sections

- 5.1.1 Space and Reach Requirements
- 5.1.4 Accessible Routes, Paths and Corridors
- 5.1.10 Gates, Turnstiles and Openings
- 5.3.3 Waiting and Queuing Areas
- 5.3.4 Information, Reception and Service Counters
- 5.3.6 Tables, Counters and Work Surfaces
- 6.2 Lighting
- 6.7 Signage and Wayfinding
- 7.1 Acoustics





Barriers and Obstacles

When designing and planning for bars, restaurants and cafeterias, one should consider that everyone has equal right to services (as defined by the law); the young and the aged, the able bodied and persons with disabilities.

With this in mind consider :

- lower sight lines;
- reduced reach;
- knee space and manoeuvring requirements of persons using wheelchairs or scooters;
- flexibility and options of seating;
- noise and lighting levels; and
- ease of use.

Design Requirements

- 1) All dining areas including raised or sunken dining areas, loggias, and outdoor seating areas:
 - a) shall be accessible; and
 - b) in buildings not equipped with elevators, an accessible means of vertical access to the mezzanine is not required under the following conditions:
 - i) the area of the mezzanine seating measures no more than 33 percent of the area of the total accessible seating area;
 - ii) the same services and décor are provided in an accessible space usable by the general public; and
 - iii) the accessible areas are not restricted to use by people with disabilities;
 - c) in retrofit situations, are not required to be accessible provided the same services and décor are provided in an accessible space usable by the general public and are not restricted to use by people with disabilities.
- 2) Fixed tables (or dining counters where food is consumed but there is no service) where provided:
 - a) at least 5 percent, but not less than one of the fixed tables (or a portion of the dining counter) shall be accessible.
 - b) shall be accessible by means of an accessible aisle between parallel edges of tables or between a wall and the table edges.

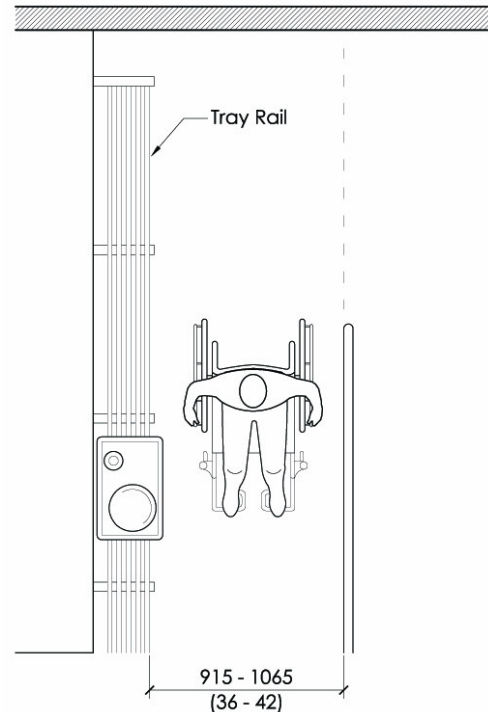

Figure 8.7(a)
Cafeteria Aisle Width

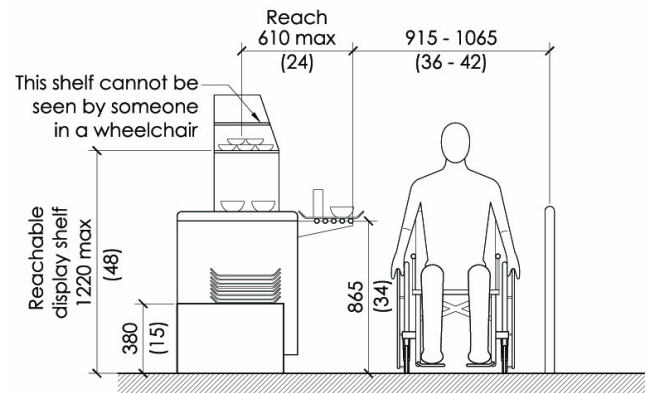

Figure 8.7(b)
Cafeteria Counters



- 3) Beverage dispensing machine areas should be accessible to individuals using mobility aids, and should be operable with one hand.
- 4) Food service lines shall incorporate the following:
 - a) a minimum clear width of 915 mm (36 in.), with a preferred clear width of 1065 mm (42 in.) to allow passage around a person using a wheelchair or scooter – **Figure 8.7(a) and 8.7(b)**; and
 - b) tray rails should be continuous to allow a tray to slide along easily, and should be mounted no higher than 865 mm (34 in.) above the floor – **Figure 8.7(b)**.
- 5) Cashier locations should include accessible aisles with clear resting surfaces for trays, etc.
- 6) A portion of counters and bars of a minimum 1525 mm (60 in.) in length, and exceeding 865mm (34 in.) in height, for consumption by customers seated on stools, or standing at the counter shall be provided in compliance with 5.3.4 *Information, Reception and Services Counters* – **Figure 8.7(b)**.
- 7) Self serve functions such as self-service shelves, dispensing devices for tableware, dishware, condiments, food, and beverages shall be installed to comply with 5.1.1 *Space and Reach Requirements*.

Related Sections

- 5.1 Access and Circulation
- 5.2 Washroom Facilities
- 5.3 Amenities
- 5.4 Systems and Controls
- 6.0 Visual Accessibility
- 7.0 Audible Accessibility



Barriers and Obstacles

Individuals should be able to access and use arena facilities regardless of their abilities or age. Wherever possible, support should be available by the facilities staff to assist individuals with varying disabilities use the arena to its fullest potential.

Design Requirements

- 1) Sporting arenas shall be accessible to all members of the general public
- 2) Accessible seating shall be provided with clear sight lines in conformance with section 7.1 *Meeting Rooms, Assembly Areas and Theatres*, and shall include:
 - a) a minimum of two accessible seats for the first 100 seats, with an additional seat for each successive 100 seats.
- 3) Access panels to the arena floor shall be a minimum clear width of 865 mm (34 in.).
- 4) Locker rooms and changing rooms shall be able to accommodate all individuals with disabilities including those who use mobility aids.
- 5) Public washrooms shall conform to section 5.2 *Washroom Facilities*.

Related Sections

- 5.1 Access and Circulation
- 5.2 Washroom Facilities
- 5.3 Amenities
- 5.4 Systems and Controls
- 6.0 Visual Accessibility
- 7.0 Audible Accessibility





Barriers and Obstacles

Ice rinks are an intrinsic part of Canadian culture and are constantly in demand and visited by a wide variety of people, including:

- families for recreation;
- seniors going to see a grandchild's hockey game or for a leisurely skate; or
- audiences going to see a figure skating pageant.

Some facilities are in such high demand, that they operate 24 hours on weekends.

Careful consideration should be given to:

- lighting levels – for different times of the day;
- wayfinding techniques, and colour contrasting, as visual aids should be employed;
- clear signage; and
- flexible and accessible dressing rooms, for all ages and genders.

Design Requirements

- 1) Indoor and outdoor ice rinks shall be accessible and usable by persons with varying disabilities.
- 2) Where viewing areas are provided they shall be accessible.
- 3) All public amenities shall be accessible.
- 4) At outdoor rinks provide:
 - a) an accessible pedestrian route from any parking areas or bus routes;
 - b) a clear space with a smooth hard surface at the entrance to the rink; and
 - c) a bench on an accessible pedestrian route, so that persons can watch or put on their skates.

Related Sections

- 5.1 Exterior Pedestrian Access
- 5.2 Washroom Facilities
- 6.0 Visual Accessibility





Barriers and Obstacles

Swimming pools are used by a wide variety of people, for a variety of reasons; the very young, seniors, for recreation, fitness, sports clubs, private parties, therapeutic programs etc. Important considerations for the disabled are:

- fully accessible change facilities;
- access into the pool – ramps are preferred as it promotes integration and independence;
- colour contrasts and changes in texture to help guide the visually impaired, (e.g., textural cues along primary travel routes and bright contrasting colours to indicate level changes or the edge of the pool); and
- consideration of warning systems for the hearing impaired (e.g., flashing lights as an alarm to evacuate the pool).

Wading pools are primarily used by young children and families. Consideration should be given to:

- access for wheelchairs and strollers on the wet surface;
- the slip resistance of the surface; and
- clear signage, and warning systems.

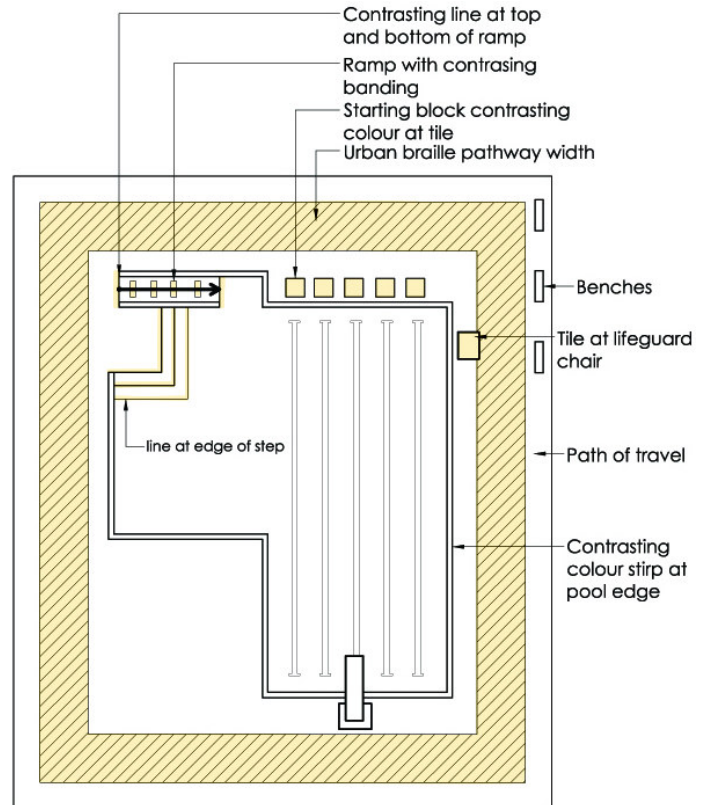

Figure 8.10(a)
Accessible Swimming Pool

Design Requirements

- 1) Newly designed or newly constructed and altered swimming pools and wading pools shall comply with this section.

Exception: An accessible route shall not be required to serve raised diving boards or diving platforms.

- 2) Access:
 - a) An accessible route shall be provided from
 - i) the front entrance to the change facilities;
 - ii) the change facilities to the deck; and
 - iii) the front entrance to the viewing area (wherever applicable).
 - b) A ramp shall be provided into the pool - **Figure 8.10(a)** – with the following considerations;
 - i) sloped no steeper than 1:8 and extending to a depth of between 610 mm minimum and 762 mm maximum below the stationary water level. This depth is necessary for individuals using the sloped entry to become buoyant



- ii) a colour-contrasting indicator at the top and bottom of the ramp;
 - iii) a high contrasting colour/pattern to differentiate the surface of the ramp from the tank;
 - iv) in a retrofit situation where the provision of a ramp is not feasible, some provision for transferring persons into the water should be provided;
 - v) clear deck space of at least 1524 mm x 1524 mm (60 in. x 60 in.) provided at all transfer areas;
 - vi) handrails that shall:
 - be provided on both sides not more than 1220 mm (48 in.) apart; and
 - shall extend at least 305 mm (12 in.) beyond the pool edge;
 - vii) positioned where it does not interfere with swimming lanes.
- c) Where stairs are provided into the pool:
- i) handrails shall extend at least 305 mm (12 in.) beyond the pool edge;
 - ii) be positioned where they do not interfere with swimming lanes; and
 - iii) be marked with a colour contrasting strip at least 50 mm (2 in.) wide at both the riser and the tread.
- d) Wading pool access should be gradual so that wheelchairs can access the pool area.
- 2) Colour Contrasting - **Figure 8.10(a)**:
- a) shall indicate pool boundaries – a high contrast colour at the edge of the pool to define the edge of the tank;
 - b) may be used to indicate the path of travel to change facilities and around obstacles on the deck;
 - c) may be used to indicate stationary objects on the pool deck with a contrasting floor pattern/ colour or the item itself being brightly coloured. These items may include:
 - i) life guard chairs;
 - ii) starting blocks;
 - iii) tie off devices; and
 - iv) diving boards;
 - d) the pool tank shall be of a light colour and contrasting to the pool deck.



- 3) Lighting
 - a) Light Fixtures at the pool shall be:
 - i) selected and positioned to minimise reflected glare on the surface; and
 - ii) positioned for easy maintenance and re-lamping.
 - b) Natural daylight should be controllable to minimise glare off the surface of the water, especially from the south and west.
 - c) Lighting levels at the pool, pool deck and change facilities shall be a minimum of 20 Lux (2 ft. candles).
- 4) Signage shall be:
 - a) suitable for persons with low vision; and
 - b) symbols wherever possible.
- 5) Pool Deck
 - a) Swimming pools should be generally of "Level deck design" to allow for easy access. Where up-stand edges are provided they should be a minimum of 205 mm (8 in.) and a maximum of 400 mm (15-3/4 in.) in height.
 - b) All materials and finishes on the pool deck or paved area around the pool should be of firm non-slip material.
 - c) Pool perimeter tiles should be non-abrasive to minimise skin damage.
 - d) Adequate drainage should be provided on the deck to quickly remove water at all times.
 - e) Drainage tiles, scuppers or trenches should be placed to minimise tripping hazards and have no openings greater than 13 mm (1/2 in.).

Related Sections

- 5.1 Access and Circulation
- 5.2 Washroom Facilities
- 5.3 Amenities
- 5.4 Systems and Controls
- 6.0 Visual Accessibility
- 7.0 Audial Accessibility





Barriers and Obstacles

Police stations should accommodate all individuals whether they are members of the general public, detainees, members of council, or police staff. While all public areas need to be fully accessible, secure areas need only provisions for accessibility.

Except as specified in this section, all common use areas shall comply with sections 5.1 Access and Circulation, 5.2 Washroom Facilities, 5.3 Amenities, 5.4 Systems and Controls, 6.0 Visual Accessibility and 7.0 Audible Accessibility.

Design Requirements

- 1) Requirements in section 5.4.2 *Emergency Exits, Fire Evacuation and Areas of Rescue Assistance* for areas of rescue assistance need not be applied under this section.
- 2) Elevators and stairs need not comply in multi-storey housing facilities where accessible cells or rooms, all common use areas serving and all public use areas are located on an accessible route.
- 3) Entrances used by the general public shall comply with section 5.1.8 *Entrances*.
 - a) Secured entrance doors and doorways are not required to have accessible door hardware if operated only by security personnel.
- 4) An accessible route shall be provided through security systems and entrances.
 - a) Where security systems, such as metal detectors, do not allow for an accessible route, an adjacent route shall be provided which is accessible.
- 5) Non-contact visiting areas shall, where provided, have the following accessible elements on an accessible route:
 - a) 5% of cubicles or counters, but not less than one, shall be accessible in conformance with section 5.3.6 *Tables, Counters and Work Surfaces* on both the visitor and detainee side. This is not required if a non-contact visiting area does not serve an accessible cell or room.
 - b) systems that allow communication through a solid partition or security glazing shall be accessible to both individuals using mobility aids and individuals who have difficulty bending.



- c) where telephone communication systems are provided, at least one shall be equipped with volume control.
- 6) A minimum of 2%, but not less than one cell shall be accessible:
 - a) At least one of each type of special cell, such as orientation, protective custody etc. shall be accessible.
 - b) A minimum of 2%, but not less than one general cell shall be equipped with audible emergency warning system, or permanently installed telephone with in the cell.
- 7) Where provided to serve accessible cells, the following elements or spaces shall be accessible and connected by an accessible route:
 - a) all doors and doorways;
 - i) secured entrances, doors and doorways only to be operated by security personnel need not be accessible;
 - b) a minimum of one toilet and one bathing facility;
 - c) a minimum of one drinking fountain;
 - d) fixed or built in tables, counters or work surfaces;
 - e) a minimum of one fixed bench;
 - f) fixed or built in storage; and
 - g) all controls intended for operation by detainees.
- 8) Accessible beds shall have manoeuvring space of at least 915 mm (36 in.) wide along one side.
- 9) Permanently installed telephones within cells shall have volume controls.
- 10) Visual alarms shall be provided where audible emergency warning systems serve occupants of cells.
 - a) Visual alarms are not required where detainees are not allowed independent means of egress.

Related Sections

- 5.1 Access and Circulation
- 5.2 Washroom Facilities
- 5.3 Amenities
- 5.4 Systems and Controls
- 6.0 Visual Accessibility
- 7.0 Audible Accessibility



Barriers and Obstacles

Long-term care facilities try to provide a home-like environment for individuals who require long-term care. Senior housing allows individuals who need some assistance to live their lives with minimal support.

Design Requirements

- 1) Long-term facilities that cater to seniors or individuals with various disabilities shall be fully accessible.
- 2) Equipment and other components that provide support to individuals with physical disabilities or intellectual disabilities should be integrated as subtly as possible.
- 3) Within individual apartments, hallways to bedroom and bathroom doorways should be a minimum of 1065 mm (42 in.)

Related Sections

- 5.1 Access and Circulation
- 5.2 Washroom Facilities
- 5.3 Amenities
- 5.4 Systems and Controls
- 6.0 Visual Accessibility
- 7.0 Audible Accessibility



Barriers and Obstacles

For seniors, people with varying disabilities and parents with small children, going to clinics and doctor's offices may be a regular activity. To make these visits quick and easy, all interior routes should be accessible and doors should allow for the free movement of persons in wheelchairs or pushing strollers.

Design Requirements

- 1) All facilities providing health care to the public should be fully accessible to seniors, persons with disabilities, and persons using mobility devices. These facilities include but are not limited to:
 - doctor's offices;
 - dental offices;
 - out-patient physiotherapists;
 - chiropractic clinics;
 - diagnostic centres; and
 - treatment centres.
- 2) All interior routes which may need to accommodate users of wheelchairs or other mobility aids should comply with section 5.1.4 *Accessible Routes, Paths and Corridors*.
- 3) Doors should be in accordance with section 5.1.9 *Doors*.

Related Sections

- 5.1.4 Accessible Routes, Paths and Corridors
- 5.1.9 Doors
- 5.1.11 Interior Routes





Barriers and Obstacles

The height of work surfaces and cooking and other appliances in typical kitchens may be too high for persons in wheelchairs or scooters to utilise. It is also important to provide enhanced lighting in areas such as over stoves or working surfaces where people, especially those with limited vision, may otherwise injure themselves.

Design Requirements

- 1) All kitchens, kitchenettes or counter areas used for food preparation should be made accessible with:
 - a) a space of no less than 1930 mm (76 in.) between counters;
 - b) a turning space of 1930 mm (76 in.) for wheelchairs and other mobility devices where kitchens have dead ends; and
 - c) clear knee space of 750 mm (29 1/2 in.) wide by 480 mm (18 3/4 in.) deep by 680 mm (26 3/4 in.) high under counters.
- 2) Cupboards and pantries shall have:
 - a) upper shelves no higher than 1370 mm (54 in.) from the floor;
 - b) if base cupboards, a toe space no less than 150 mm by 230 mm (6 in. by 9 1/4 in.); and
 - c) "D"-style handles mounted at:
 - i) the bottom of upper cabinets; and
 - ii) the top of base cabinets.
- 3) Side-by-side refrigerator and freezer units provide easier access for persons using mobility devices.
- 4) Cooking ranges should have:
 - a) controls on front or side panels to avoid burns; and
 - b) automatic off switches to control unattended burners.
- 5) A clear counter space of 305 mm (12 in.) wide should be provided on each side of cooking ranges for safe operation.
- 6) Microwaves should:
 - a) be installed at counter height;
 - b) have a clear space in front to allow easy transfer of food; and
 - c) be larger models where possible.
- 7) Where hot water pipes below sinks may interfere with the space occupied by a person's legs, the pipes should be insulated.

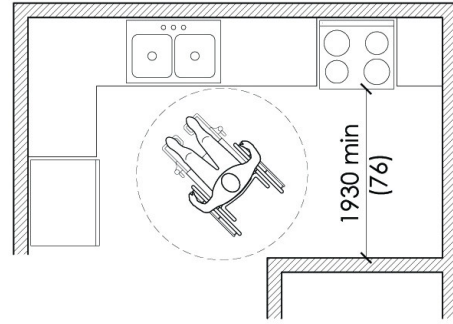

Figure 8.14(a)
"Dead End" Kitchen Layout

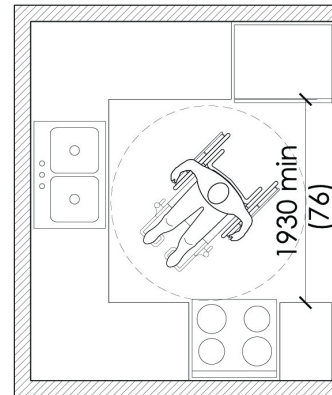

Figure 8.14(b)
"Dead end" Kitchen Layout

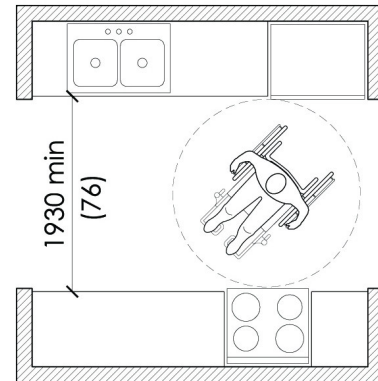

Figure 8.14(c)
"Galley" Forward Reach



- 8) Duplex receptacles should be mounted no higher than 1065 mm (42 in.) when located above the counter.
- 9) Additional lighting should be provided over the sink, cooking range, and work surfaces.

Related Sections

- 5.1.1 Space and Reach Requirements
- 5.1.4 Accessible Routes, Paths and Corridors
- 5.3.6 Tables, Counters and Work Surfaces
- 6.2 Lighting



Barriers and Obstacles

While residential bathrooms should comply with earlier sections of this document, some variations may occur.

Design Requirements

- 1) Residential bathrooms - **Figure 8.15(a)** - shall accommodate the use of mobility aids and commode chairs.
- 2) Where possible, space for wheelchair access to a shower should be used instead of a standard bathtub.
- 3) Where a bathtub is used:
 - a) it should be a minimum of 1500 mm (59 in.) long – **Figure 8.15(a)**;
 - b) a clear floor space of at least 750 mm (29 1/2 in.) in width shall be provided along the full length of the open side of the tub;
 - c) a transfer seat shall be provided level with the tub rim:
 - i) 380mm (15 in.) deep transfer seat is recommended; and
 - ii) transfer seat should be provided at the opposite end of the bathtub as the controls;
 - d) grab bars in compliance with section 5.2.10 *Grab Bars* should be installed, however, it is often preferable to install such aids to suit a specific person's needs, after they have moved into the space.
- 4) Bathtubs and showers shall have non-slip surfaces in the standing area.

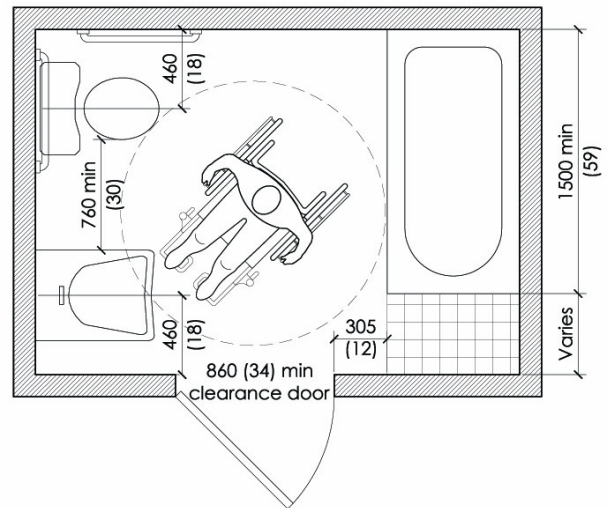

Figure 8.15(a)
Residential Bathroom

Related Sections

- 5.1 Access and Circulation
- 5.2 Washroom Facilities
- 5.3 Amenities
- 5.4 Systems and Controls
- 6.0 Visual Accessibility
- 7.0 Audible Accessibility





Barriers and Obstacles

A typical bedroom's area may not allow for ease of turning of mobility devices. It is also important to allow enough space for persons using mobility devices to transfer from aids to the bed.

Design Requirements

- 1) Provide enough turning space for persons using wheelchairs or scooters in the master bedroom at specific spots such as:
 - doorways;
 - closets; and
 - beside the bed.
- 2) Hardware on doors, closets, cabinet work, and windows should be easy to operate and not require fine finger control, tight grasping, pinching, or twisting of the wrist to operate.

Related Sections

- 5.1.4 Accessible Routes, Paths and Corridors
- 5.1.9 Doors
- 5.1.11 Interior Routes

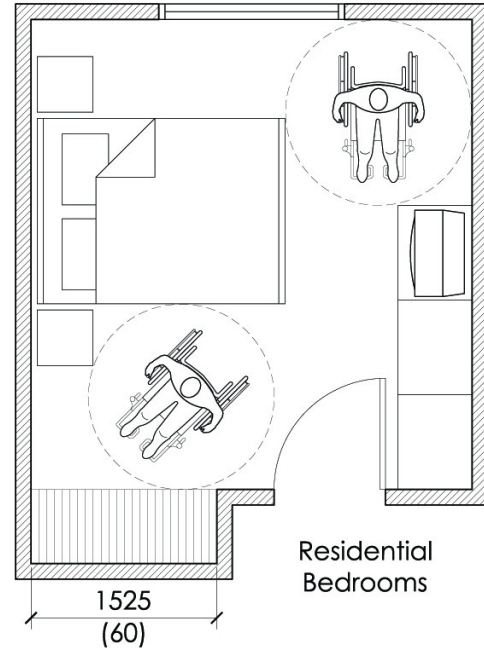

Figure 8.16(a)
Residential Bedroom





Barriers and Obstacles

Transportation is essential to all members of a community. Forms of transportation include:

- public bus;
- private bus;
- taxi;
- train; and
- airplane.

Design Requirements

- 1) Transit facilities serving one or more modes of transit, such as a GO station, should at all levels, facilities and amenities be accessible to all individuals
- 2) Train platforms or boarding platforms, where used, should allow individuals using mobility aids safe access.
- 3) Platform edges shall be marked with a continuous detectable warning surface in compliance with section 6.8 *Detectable Warning Surfaces*.
- 4) Platform and boarding service level lighting should be a minimum of 100 lux (10 ft. - candles).
- 5) Ticketing areas should have a minimum lighting level of 200 lux (20 ft.-candles).
- 6) Where special lifting devices are used to aid individuals using mobility aids, sufficient area should be provided for waiting passengers who use mobility aids.
- 7) Seating should be provided on platforms or close to boarding areas for seniors or individuals with limited stamina.
- 8) Bus shelters shall:
 - a) be located on firm, level surface at the same level as the surrounding sidewalk or walkway;
 - b) have a minimum clearance of 1220 mm (48 in.) on at least two sides of the shelter; and
 - c) provide a clear view of oncoming traffic.
- 9) Surrounding street furniture shall not impede bus stops.

Related Sections

- 5.1 Access and Circulation
- 5.2 Washroom Facilities
- 5.3 Amenities
- 5.4 Systems and Controls
- 6.0 Visual Accessibility
- 7.0 Audible Accessibility

The detectable warning surface should be positioned parallel to the open platform edge. It should extend for the full length of the platform and it should maintain a depth of 610 mm from the open edge of the platform.

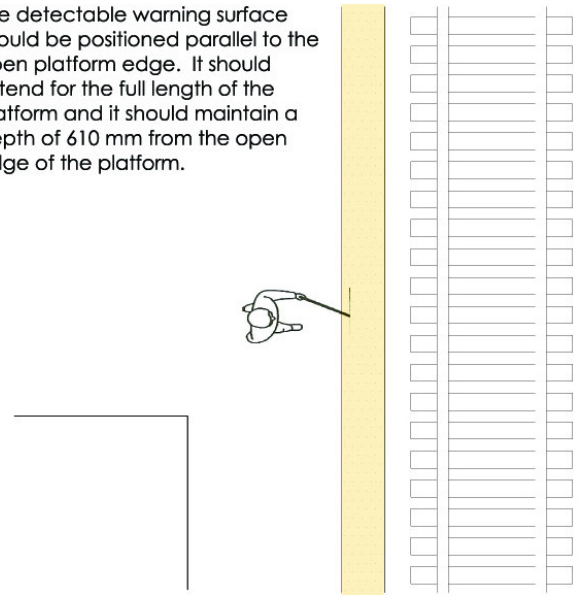

Figure 8.17(a)
Train Boarding Platform





Barriers and Obstacles

Air transportation is becoming more attainable with the rise of globalisation and increased demand from the developing world. Airports are becoming a hub for diversity, with regard to cultural expectations, age, language, physical abilities and much more.

Such a specialised building obviously takes great planning on many levels, and issues pertaining to universal access can be further affected by developing technologies (e.g., handrails that can communicate through sound).

Design Requirements

In addition to related sections, it is suggested that airports incorporate:

- 1) amplified handsets at ticket and service counters;
- 2) visual paging systems along with the audible paging system;
- 3) closed caption decoders at all information kiosks;
- 4) facilities for guide dogs, such as dog runs; and
- 5) access to wheelchair lifts when boarding a ground loaded aircraft.

Related Sections

- 5.0 Physical Accessibility
- 6.0 Visual Accessibility
- 7.0 Audible Accessibility



Appendices

Appendix A.....Acknowledgments
 Appendix B Bibliography
 Appendix C Change Request Form



Appendix A - Acknowledgements

The City of Hamilton would like to acknowledge and thank all of the individuals who have participated in the preparation of the newly revised City of Hamilton's Barrier-Free Design Guidelines 2006.

City of Hamilton Council

Mayor Larry Di Ianni
Office of the Mayor

Councillor Brian McHattie
WARD 1

Councillor Bob Bratina
WARD 2

Councillor Bernie Morelli
WARD 3

Councillor Sam Merulla
WARD 4

Councillor Chad Collins
WARD 5

Councillor Tom Jackson
WARD 6

Councillor Bill Kelly
WARD 7

Councillor Terry Whitehead
WARD 8

Councillor Phil Bruckler
WARD 9

Councillor Maria Pearson
WARD 10

Councillor David Mitchell
WARD 11

Councillor Murray Ferguson
WARD 12

Councillor Art Sampson
WARD 13

Councillor Dave Braden
WARD 14

Councillor Margaret McCarthy
WARD 15

Appendix A - Acknowledgements

Barrier-Free Design Guidelines 2006 Committee

The City of Hamilton would like to extend a very special thank you to the Barrier-Free Design Guidelines Committee as listed below. This group met on a monthly basis and dedicated much of their personal time on this project. Their assistance was very much appreciated and their involvement led to a marked improvement to the final product.

David Barefoot

Sheila Behnke

Darlene Burkett

Shelley Cavill

Julia Dawn-Juarez

Emily Green

Syd Green

Maggie Hughes

Myra Kennedy

Chris Kenopic

Ivy Morton

Mary Sinclair

Mary Smithson

Ron Smithson

Gay Walton

Staff Resources:

Maxine Carter, Customer Service, Access & Equity, Corporate Services

Clark Euale, Capital Planning and Implementation, Public Works

Consultants:

R.F. Lintack Architect Incorporated

Appendix A - Acknowledgements

City of Hamilton Advisory Committee for Persons with Disabilities

In addition, the City of Hamilton would like to extend appreciation to the City of Hamilton Advisory Committee for Persons with Disabilities who provided input during the preparation of the guidelines, and who continue to provide valuable advice to the City on behalf of persons with disabilities.

Tim Nolan, Chair

Darlene Burkett

Patty Cameron

Janice Ferguson

John Fuca

Anthony Haynes

Brian Lane

Sandi Mugford

Maria Ann Pennacchietti

Carol Sheppard

Mary Smithson

Kimberly Walker

Gay Walton

Appendix A - Acknowledgements

City of Hamilton Staff

A special thank you also goes out to the teams from the City of Hamilton's Customer Service, Access & Equity Division of the Corporate Services Department, and the Capital Planning and Implementation Division of the Public Works Department. Particular thanks are extended to Maxine Carter, Access and Equity Coordinator, who provided tremendously helpful advice throughout this project and was instrumental in the overall success of the newly revised, Barrier-Free Design Guidelines 2006. Special thanks also to Clark Euale, Project Manager, for his leadership efforts and for working towards a comprehensive update of the Barrier Free Design Guidelines for the City of Hamilton.

The assistance of a group of dedicated staff who provided advice and input to the development of the guidelines was also invaluable. Particular thanks are extended to the following members of staff who participated in and assisted with the development of the guidelines.

Al Dore, Operations & Maintenance
Public Works

Amy Groleau, CP&I
Public Works

Andy McLaughlin, Transit
Public Works

Anna Bradford, Culture & Recreation
Public Health & Community Services

Bob Zolaturiuk, Budgets & Finance
Corporate Services

Carolyn Bish, Customer Service, Access & Equity, Corporate Services

Chris McCafferty, CP&I
Public Works

Clark Euale, CP&I
Public Works

Craig Murdoch, Waste Management
Public Works

Cynthia Graham, CP&I
Public Works

Dale Wood, Culture & Recreation
Public Health & Community Services

Dan Chauvin, Water & Wastewater
Public Works

Dio Ortiz, Building & Licensing
Planning & Economic Development

Jerry van den Heuvel
HECFI

Jim Doyle, Emergency Services
Hamilton Emergency Services

Joanne Leung, Development & Real Estate
Planning & Economic Development

John Serafini, Health, Safety & WSIB
Public Works

Keith Extance, Housing
Public Health & Community Services

Ken d'Andrade, Development & Real Estate, Planning & Economic Development

Lawrence Stasiuk, CP&I
Public Works

Les Fenyvesi, Health, Safety & WSIB
Human Resources

Linda Tattrie, Fleet & Facilities
Public Works

Marilyn Preston, Operations & Maintenance, Public Works

Maxine Carter, Customer Service, Access & Equity, Corporate Services

Michael Hill, Budgets & Finance
Corporate Services

Paul Mallard, Development & Real Estate
Planning & Economic Development

Appendix A - Acknowledgements

Ed Switenky, Operations & Maintenance
Public Works

Fred Elbe, Housing
Planning & Economic Development

Gary Moore, CP&I
Public Works

Hank Wroblewski, Culture & Recreation
Public Health & Community Services

Jennifer Chypyha, Administration
Human Resources

Jerry Parisotto, CP&I
Public Works

Peter MacNeil, ITS
Corporate Services

Robert Norman, CP&I
Public Works

Rom D'Angelo, Fleet & Facilities
Public Works

Vimal Sarin, Housing
Public Health & Community Services

Wray Oakes, Operations & Maintenance
Public Works

Appendix A - Acknowledgements

Finally, thanks are extended to the senior management staff of the City of Hamilton, who dedicated resources to this project, and continue to work towards facilitating the development, approval and implementation of these guidelines.

City of Hamilton Departments/Divisions

Glen Peace, City Manager

Jim Kay, General Manager, Chief
Emergency Services

Gary Beasley, Director
Fire Operations/Deputy Chief

Joseph Rinaldo, General Manager
Finance & Corporate Services

Christine Swenor, Director
ITS Operations

Jane Lee, Director
Customer Service, Access & Equity

Catherine Graham, General Manager
Human Resources

Lee Ann Coveyduck, General Manager
Planning & Development

Tom Redmond, Director
Building & Licensing

Tim McCabe, Director
Development & Real Estate

Joe-Anne Priel, General Manager
Public Health & Community Services

Vicki Woodcox, Director
Housing Branch

Bill Fenwick, Director
Culture & Recreation

Scott Stewart, General Manager
Public Works

Gerry Davis, Director
Capital Planning & Implementation

John Mater, Director
Fleet & Facilities

Bryan Shynal, Director
Operations & Maintenance

Don Hull, Director
Transit

Beth Goodger, Director
Waste Management

Jim Harnum, Senior Director
Water/Wastewater

Abdul Khan, Director
Water & Wastewater Treatment

Ken Roberts, Chief Librarian
Hamilton Public Library

Bill Guise, Director, Finance & Facilities
Hamilton Public Library

Duncan Gillespie, Interim CEO
Hamilton Entertainment & Convention
Facilities Inc.

Brad Calder, Director of Business Services
Hamilton Entertainment & Convention
Facilities Inc.

Appendix B – Bibliography

Barrier Free Design Sub-Committee A Sub Committee of Regional Advisory Center for Persons with Physical Disabilities, Regional Municipality of Hamilton Wentworth and the Corporation of the City of Hamilton, Barrier Free Design Guidelines, Hamilton, 1994

Ministry of Municipal Affairs and Housing, Ontario Building Code – Part 3.8, Ontario, Ministry of Municipal Affairs and Housing, 1997

Ministry of Municipal Affairs and Housing, Illustrated Guide to the Ontario Building Code 1997, Ontario, Ministry of Municipal Affairs and Housing, 1997

Canadian Guidelines Association, Accessible Design for the Built Environment, Canadian Guidelines Association, 2004

Designable Environments Inc., City of London, Facility Accessibility Design Guidelines, City of London, 2001

Diversity Management and Community Engagement Strategic and Corporate Policy / Healthy City Office, City of Toronto Accessibility Design Guidelines, Healthy City Office, 2003



Appendix C – Change Request Form

**REQUEST FOR CHANGE(S) TO THE
CITY OF HAMILTON
BARRIER-FREE DESIGN GUIDELINES**

Mail to: Corporate Services Dept.
Customer Service, Access & Equity
Attention: BARRIER-FREE DESIGN GUIDELINES
City of Hamilton
71 Main Street West
Hamilton, Ontario, L8P 4Y5

Name: _____ Phone: () _____

Address: _____

Company or Organization: _____

Email Address: _____

PROPOSED CHANGE:

PLEASE INCLUDE SECTION, SUB-SECTION, AND PAGE NUMBER IN ORDER TO ALLOW US TO ACCURATELY LOCATE THE REQUESTED REVISION. PLEASE INCLUDE THE REVISED WORDING OR DIMENSIONS OR PROVIDE A DETAILED SUMMARY OF YOUR SUGGESTION. THIS MAY ALSO BE ATTACHED SEPARATELY. THE CITY OF HAMILTON WILL NOT GUARANTEE THAT THESE COMMENTS WILL BE INCLUDED IN THE NEXT VERSION OF THIS GUIDELINE. WE WILL REVIEW THESE COMMENTS ON AN ANNUAL BASIS AND WILL TAKE YOUR COMMENTS INTO CONSIDERATION WHEN UPDATING. THANK YOU FOR YOUR INTEREST IN IMPROVING OUR BARRIER-FREE GUIDELINES.

REASONS FOR CHANGE:

(attach additional information if required)

